



Subject Code: 804

AUTOMOTIVE

Job Role: AUTOMOTIVE SERVICE TECHNICIAN

Class- XI

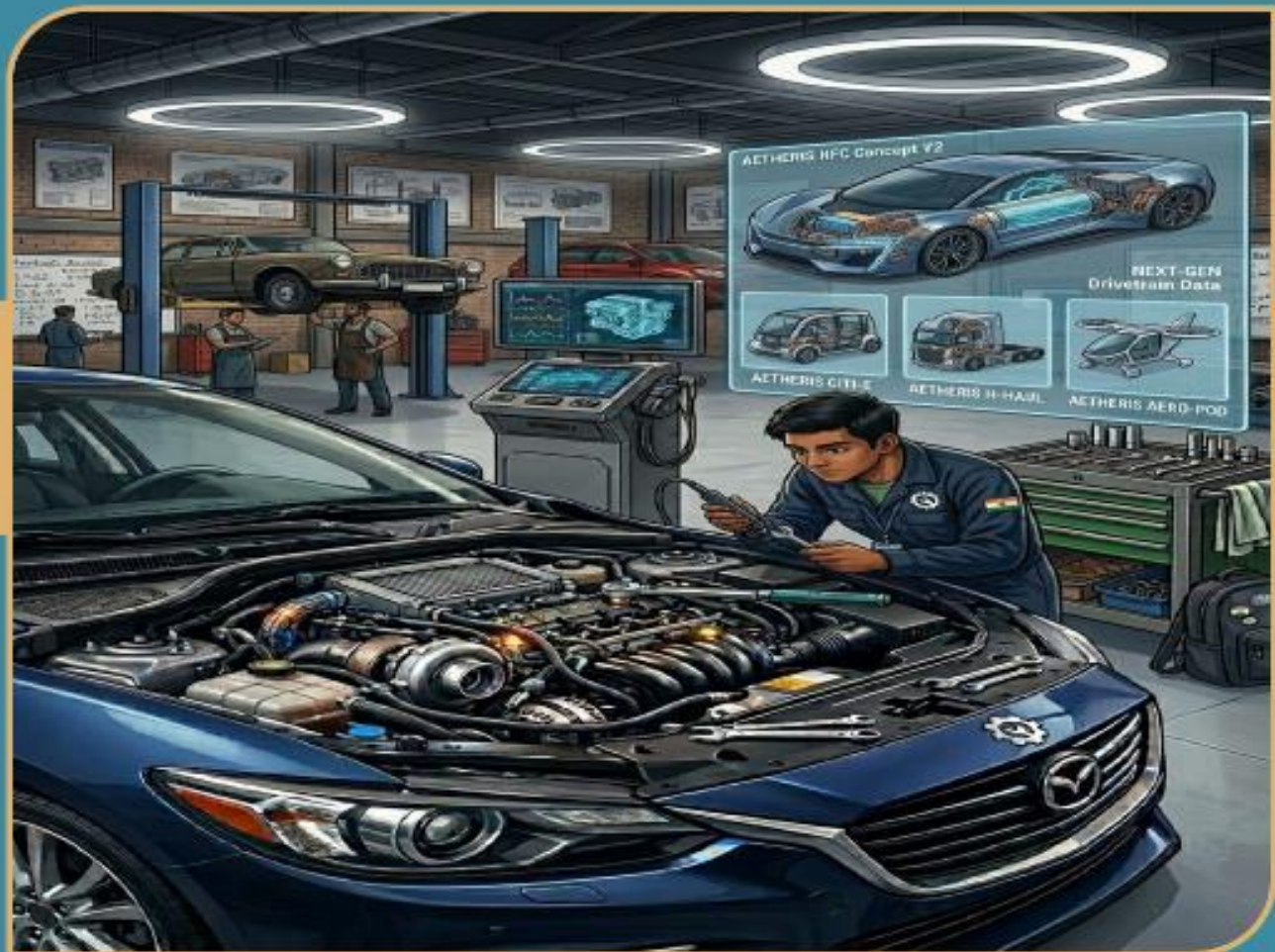

CENTRAL BOARD OF SECONDARY EDUCATION

CBSE INTEGRATED OFFICE COMPLEX, SECTOR-23, PHASE - 1, DWARKA NEW DELHI - 110077

AUTOMOTIVE

SUBJECT CODE: 804

CLASS XI

STUDENT HANDBOOK

JOB ROLE- Automotive Service Technician



CENTRAL BOARD OF SECONDARY EDUCATION

**CBSE INTEGRATED OFFICE COMPLEX, SECTOR-23, PHASE - 1, DWARKA NEW
DELHI - 110077**

भारत का संविधान

उद्देशिका

हम, भारत के लोग, भारत को एक सम्पूर्ण 'प्रभुत्व-संपन्न समाजवादी पंथनिरपेक्ष लोकतंत्रात्मक गणराज्य बनाने के लिए, तथा उसके समस्त नागरिकों को:

सामाजिक, आर्थिक और राजनैतिक न्याय,
विचार, अभिव्यक्ति, विश्वास, धर्म
और उपासना की स्वतंत्रता,
प्रतिष्ठा और अवसर की समता

प्राप्त कराने के लिए

तथा उन सब में व्यक्ति की गरिमा

और राष्ट्र की एकता और अखंडता

सुनिश्चित करने वाली बंधुता बढ़ाने के लिए

दृढ़संकल्प होकर अपनी इस संविधान सभा में आज तारीख 26 नवम्बर, 1949 ई० को एतद्वारा इस संविधान को अंगीकृत, अधिनियमित और आत्मार्पित करते हैं।

1. संविधान (बयालीसवां संशोधन) अधिनियम, 1976 की धारा 2 द्वारा (3.1.1977) से "प्रभुत्व-संपन्न लोकतंत्रात्मक गणराज्य" के स्थान पर प्रतिस्थापित।
2. संविधान (बयालीसवां संशोधन) अधिनियम, 1976 की धारा 2 द्वारा (3.1.1977) से "राष्ट्र की एकता" के स्थान पर प्रतिस्थापित।

भाग 4 क

मूल कर्तव्य

51 क. मूल कर्तव्य - भारत के प्रत्येक नागरिक का यह कर्तव्य होगा कि वह -

- (क) संविधान का पालन करे और उसके आदर्शों, संस्थाओं, राष्ट्रध्वज और राष्ट्रगान का आदर करे;
- (ख) स्वतंत्रता के लिए हमारे राष्ट्रीय आंदोलन को प्रेरित करने वाले उच्च आदर्शों को हृदय में संजोए रखे और उनका पालन करे;
- (ग) भारत की प्रभुता, एकता और अखंडता की रक्षा करे और उसे अक्षुण्ण रखे;
- (घ) देश की रक्षा करे और आह्वान किए जाने पर राष्ट्र की सेवा करे;
- (ङ) भारत के सभी लोगों में समरसता और समान भ्रातृत्व की भावना का निर्माण करे जो धर्म, भाषा और प्रदेश या वर्ग पर आधारित सभी भेदभाव से परे हों, ऐसी प्रथाओं का त्याग करे जो स्त्रियों के सम्मान के विरुद्ध हैं;
- (च) हमारी सामासिक संस्कृति की गौरवशाली परंपरा का महत्त्व समझे और उसका परिरक्षण करे;
- (छ) प्राकृतिक पर्यावरण की जिसके अंतर्गत वन, झील, नदी, और वन्य जीव हैं, रक्षा करे और उसका संवर्धन करे तथा प्राणिमात्र के प्रति दयाभाव रखे;
- (ज) वैज्ञानिक दृष्टिकोण, मानववाद और ज्ञानार्जन तथा सुधार की भावना का विकास करे;
- (झ) सार्वजनिक संपत्ति को सुरक्षित रखे और हिंसा से दूर रहे;
- (ञ) व्यक्तिगत और सामूहिक गतिविधियों के सभी क्षेत्रों में उत्कर्ष की ओर बढ़ने का सतत प्रयास करे जिससे राष्ट्र निरंतर बढ़ते हुए प्रयत्न और उपलब्धि की नई उंचाइयों को छू ले;
- (ट) यदि माता-पिता या संरक्षक है, छह वर्ष से चौदह वर्ष तक की आयु वाले अपने, यथास्थिति, बालक या प्रतिपाल्य के लिये शिक्षा के अवसर प्रदान करे।

1. संविधान (छयासीवां संशोधन) अधिनियम, 2002 द्वारा प्रतिस्थापित।

THE CONSTITUTION OF INDIA

PREAMBLE

WE, THE PEOPLE OF INDIA, having solemnly resolved to constitute India into a '**SOVEREIGN SOCIALIST SECULAR DEMOCRATIC REPUBLIC**' and to secure to all its citizens :

JUSTICE, social, economic and political;

LIBERTY of thought, expression, belief, faith and worship;

EQUALITY of status and of opportunity; and to promote among them all

FRATERNITY assuring the dignity of the individual and the² unity and integrity of the Nation;

IN OUR CONSTITUENT ASSEMBLY this twenty-sixth day of November, 1949, do **HEREBY ADOPT, ENACT AND GIVE TO OURSELVES THIS CONSTITUTION.**

1. Subs, by the Constitution (Forty-Second Amendment) Act. 1976, sec. 2, for "Sovereign Democratic Republic" (w.e.f. 3.1.1977)
2. Subs, by the Constitution (Forty-Second Amendment) Act. 1976, sec. 2, for "unity of the Nation" (w.e.f. 3.1.1977)

THE CONSTITUTION OF INDIA

Chapter IV A

FUNDAMENTAL DUTIES

ARTICLE 51A

Fundamental Duties - It shall be the duty of every citizen of India-

- (a) to abide by the Constitution and respect its ideals and institutions, the National Flag and the National Anthem;
- (b) to cherish and follow the noble ideals which inspired our national struggle for freedom;
- (c) to uphold and protect the sovereignty, unity and integrity of India;
- (d) to defend the country and render national service when called upon to do so;
- (e) to promote harmony and the spirit of common brotherhood amongst all the people of India transcending religious, linguistic and regional or sectional diversities; to renounce practices derogatory to the dignity of women;
- (f) to value and preserve the rich heritage of our composite culture;
- (g) to protect and improve the natural environment including forests, lakes, rivers, wild life and to have compassion for living creatures;
- (h) to develop the scientific temper, humanism and the spirit of inquiry and reform;
- (i) to safeguard public property and to abjure violence;
- (j) to strive towards excellence in all spheres of individual and collective activity so that the nation constantly rises to higher levels of endeavour and achievement;
- ¹(k) to provide opportunities for education to his/her child or, as the case may be, ward between age of 6 and 14 years.

1. Subs, by the Constitution (Eighty-Sixth Amendment) Act. 2002.

AUTOMOTIVE (SUBJECT CODE: 804)

CLASS XI – STUDENT HANDBOOK | JOB ROLE: Automotive Service Technician

Second Edition: 2026–27

© Central Board of Secondary Education, New Delhi, 2026

All rights reserved. No part of this publication may be reproduced, stored in a retrieval system, or transmitted in any form or by any means, electronic, mechanical, photocopying, recording, or otherwise, without the prior written permission of the Central Board of Secondary Education.

Published by the Secretary, Central Board of Secondary Education

CBSE Integrated Office Complex, Sector-23, Phase-1, Dwarka, New Delhi – 110077

Website: www.cbse.gov.in

Disclaimer

The software tools, websites, and third-party resources referenced in this handbook are mentioned for educational purposes only. CBSE does not endorse any commercial product or service. Software availability, pricing, and features may change; students and teachers are advised to verify current information from official sources. AI-generated images used in this book have been created for illustrative purposes under the supervision of the content development team.

ACKNOWLEDGEMENT

Patron

Mr. Prashant Lokhande, IAS

Chairperson

Central Board of Secondary Education, New Delhi

Guidance and Support

Dr. Biswajit Saha

Professor & Director

Department of Skill Education, CBSE, New Delhi

Education Value Adder, Curator and Coordinator

Mr. Satish Pahal

Assistant Professor & Joint Director

Department of Skill Education, CBSE, New Delhi

Content Developers

Mr. Vinod K Dwivedi

Subject Matter Expert

(Automotive Service)

Automotive Skills Development Council (ASDC), Lucknow (UP)

Mr. Rakesh Nagpal

Director

Satyam Group, New Delhi

Mr. Debkumar Dasgupta

Ex. DGM

Hero Moto Corp, Kolkata (WB)

Mr. Ajay Gupta

Deputy General Manager

VE Commercial Vehicles India Pvt. Ltd.,
Pithampur (MP)

Mr. Vikram

Vocational Teacher (Automotive)

Sarvodaya Bal Vidyalaya (SBV), Nilothi, New Delhi

Mr. Vipin Yadav

Lecturer

Govt Polytechnic Loharu, Technical Education Deptt,
Haryana

Mr. Sandeep Singh

Vocational Teacher (Automotive)

Government Model Sanskriti Senior Secondary School (GMSSSS) Cheeka, Kaithal (HR)

Content Editors

Mr. Manik Gupta

Content Head

Proxcel Services Pvt. Ltd, New Delhi

Ms. Garima Jhamb

Assistant Vice President

NEP Implementation & International Initiatives

Automotive Skills Development Council (ASDC), New Delhi

Preface

The automotive industry stands as one of the most transformative and influential sectors in today's global economy, shaping the way people and goods move across the world. From the earliest invention of the wheel to the development of advanced electric and intelligent vehicles, the journey of automobiles reflects human innovation, engineering excellence, and technological evolution. In India, the automotive sector continues to expand rapidly, contributing significantly to economic growth, employment generation, and technological advancement. This dynamic landscape presents immense opportunities for young learners to build meaningful careers in automotive sales, service, and technical domains.

Aligned with the National Skill Qualification Framework (NSQF) and developed in collaboration with the Automotive Skills Development Council (ASDC), this course is designed to bridge the gap between academic learning and industry requirements. The *“Automotive — Class XI Student Handbook”* serves as a comprehensive guide that introduces learners to the fundamentals of the automotive world while building practical, job-ready skills relevant to real workplace scenarios.

Within this handbook, students will explore the evolution of automobiles—from the invention of the wheel to modern-day vehicles—and gain insights into the Indian automobile market and its key players. The content further covers essential areas such as vehicle classification, workplace safety, product knowledge, customer handling, sales and service roles, and road safety practices. It also introduces learners to workshop tools, basic automotive technology, routine maintenance, and the environmental impact of automobiles, preparing them for both technical understanding and responsible professional conduct.

Developed under the guidance of the Central Board of Secondary Education (CBSE) and supported by industry experts and educators, this handbook ensures a balanced approach between conceptual clarity and hands-on learning. Activities, examples, and structured modules are designed to make learning engaging, practical, and aligned with industry expectations.

Whether you aspire to become an automotive technician, service professional, sales consultant, or pursue advanced studies in automotive engineering, this handbook lays a strong foundation for your journey. It equips you not only with technical knowledge but also with professional skills, ethics, and awareness required to succeed in a rapidly evolving industry.

We invite you to embark on this exciting journey into the world of automobiles and discover the skills that will drive your future forward.

Chairperson, CBSE

Table of Contents

S.No.	Modules and Units	Page No.
1.	Evolution of Automobiles & Indian Automobile Market	1
	Session I: Evolution of Automobiles	2
	Session II: Classification of Vehicles and Structure	11
	Session III: Indian Automobile Market and Prominent Automobile Manufacturers in India	22
2.	Introduction to Automobile dealership and Role of Sales & Service Personnel	27
	Session I: Sub-sectors of Automotive Industry & Automotive Dealership Structure	28
	Session II: Introduction to Sales Consultant Role & Responsibilities	33
	Session III: Importance of Sales in Business Growth	35
	Session IV: Introduction to Role of Service Technician & Responsibilities	38
	Session V: Importance of Service in Business Growth	40
3.	Health and Safety at Workplace	41
	Session I: Workplace Safety Rules	42
	Session II: Personal Hygiene and Cleanliness	48
	Session III: Fire Safety and Emergency Procedures	53
	Session IV: Safe Handling of Equipment	60
	Session V: First Aid Basics	62
4.	Basic Product Knowledge (Automobile)	67
	Session I: Importance of Product Knowledge in Sales & Service	68
	Session II: Anatomy of all type of vehicles	71
5.	Sales & Service Personnel grooming and Ethics	75
	Session I: Sales & Service Personnel Grooming and Professional Behaviour	76
	Session II: Ethics in Sales and Service and Customer Dealing	78
6.	Road Safety	80
	Session I: Introduction and importance of Road Safety	81
	Session II: Key Road Safety Principles and Safe Driving Techniques	84
7.	Workshop layout, Tools & Equipment	86
	Session I: Workshop layout	87

	Session II: Workshop Tools & Equipment	88
8.	Automotive Technology & Routine Maintenance (Engine)	102
	Session I: Engine and its systems	103
	Session II: Routine maintenance and settings in Engine	119
9.	Automobiles and Our Environment	127
	Session I: Pollutants from Automobile and BS-6 norms	128
	Session II: Changes incorporated to make vehicles BS-6 complaint	137
	Session III: PUC certification	140

Unit I

Evolution of Automobiles & Indian Automobile Market

Session I: Evolution of Automobiles

Introduction

You must have heard the word **Automobile**. Meaning of an automobile can be auto car, motor car or car. It is a wheeled motor vehicle used for transporting goods or passengers, which also carries its own engine or motor. The word automobile comes from the Ancient Greek word (autos, "self") and the Latin *mobilis* ("movable"); therefore, automobile means *a vehicle that moves itself*. The alternative name car is believed to originate from the Latin word *carrus* or *carrum* ("wheeled vehicle"), or the Middle English word *carre* ("cart") (from Old North French).



These words in turn are said to have originated from the Gaulish word *karros* (a Gallic Chariot).

Most definitions of the term specify that Automobiles are designed to run primarily on roads, to have seating for one to eight people, to typically have four wheels, and to be constructed principally for the transport of people and goods.

In this Unit, you will develop an understanding of the concept of wheel and role of wheel cart. You will also learn various stages of development over several hundred years that made possible the invention of an Automobile as we know it today. You will understand how various automobiles were developed in past.

Invention of Wheel

The Wheel is considered as one of the most important mechanical inventions of all time. The wheel has been used by man since the beginning of civilization. Most primitive technologies since the invention of the wheel have been based on its principles.

The invention of the Wheel was perhaps in the late Neolithic age. It is likely that it happened along with other technological advances that gave rise to the early Bronze Age.

4500 BC (Before Christ): Invention of the potter's wheel, Chalcolithic (Ubaid period)

4500–3300 BC : Chalcolithic, earliest wheeled vehicles, domestication of the horse

3300–2200 BC : Early Bronze Age

2200–1550 BC : Middle Bronze Age, invention of the spoked wheel and the Chariot.

Since the industrial revolution, the Wheel has been a basic element of nearly every machine constructed by mankind. While the exact time and place of the invention of the wheel have been disputed but its beginnings can be seen across ancient civilizations.

History tells us that wheel was most likely invented in Mesopotamia (modern day Iraq) around 3500 BC. This means that the Wheel is about 5,500 years old!

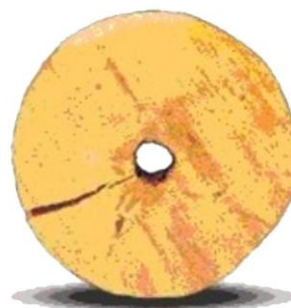

The first use of the wheel for transportation was in Mesopotamian chariots in 3200 BC. There are many references to wheeled chariots in Indian mythology also dating to around 3,000 BC. It is interesting to note that wheels may have been used in industrial or manufacturing applications before they were used on vehicles.

Egyptians started using wheel with spokes, first in chariots around 2000 BC and use of wheels seems to have started in Europe by 1400 BC.

Early wheels were simple wooden disks with a hole for the axle. Because of the structure of wood, a horizontal slice of a tree trunk is not suitable, as it does not have the structural strength to support weight without collapsing, rounded pieces of longitudinal boards are required.

The oldest known example of a wooden wheel and its axle were found in 2003 in the Ljubljana Marshes some 20 km south of Ljubljana, the capital of Slovenia. According to the radio carbon dating, it is between 5,100 and 5,350 years old. It has a diameter of 72 centimeters (28") and has been made of ash wood, whereas its axle has been made of oak.

The spoked wheel was invented more recently, and allowed the construction of lighter and swifter vehicles. In the Harappan civilization of the Indus Valley and North Western India, we find toy-cart wheels made of clay with spokes painted or in relief, and the symbol of the spoked wheel in the script of the seals, already in the second half of the 3rd millennium BC.

The earliest known examples of wooden spoked wheels are in the context of the Andronovo culture, dating to ca 2000 BC. Soon after this, horse cultures of the Caucasus region used horse-drawn spoked -wheel war chariots for the greater part of three centuries. They moved deep into the Greek Peninsula where they joined with the existing Mediterranean peoples to give rise, eventually, to classical Greece after the breaking of Minoan dominance and consolidations led by pre-classical Sparta and Athens. Celtic Chariots introduced an iron rim around the wheel in the 1st millennium BC. The spoked wheel was in continued use without major modification until the 1870s, when wire wheels and pneumatic tires were invented.

The invention of the wheel has also been important for technology in general, important applications including the water wheel, the cogwheel (see also antikythera mechanism), the spinning wheel and the astrolabe or torquetum. More modern descendants of the wheel include the propeller, the jet engine, the flywheel (gyroscope) and the turbine.

Therefore we see that a **wheel** is a circular component that can rotate on its centre. Wheels, in conjunction with axles, allow heavy objects to be moved easily while supporting a load. The wheel is the main component of the wheel and axle assembly. Wheel and axle were used in the first carriages. We shall learn about these later.

A wheel greatly reduces friction by facilitating motion by rolling together with the use of axles. In order for wheels to rotate, a moment needs to be applied to the wheel about its axis, either by way of gravity, or by application of another external force.

The classic spoked wheel with hub and iron rim was in use from about 500 BC (Iron Age Europe) until the 20th century AD (Anno Domini). We can see the importance of wheel in various

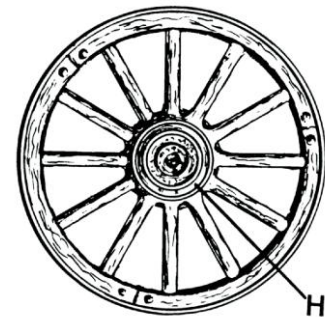

places and its role. Our national flag also contains a circle like wheel. Wheel is very important in our daily life. Some of important drawings of wheel are given herewith.

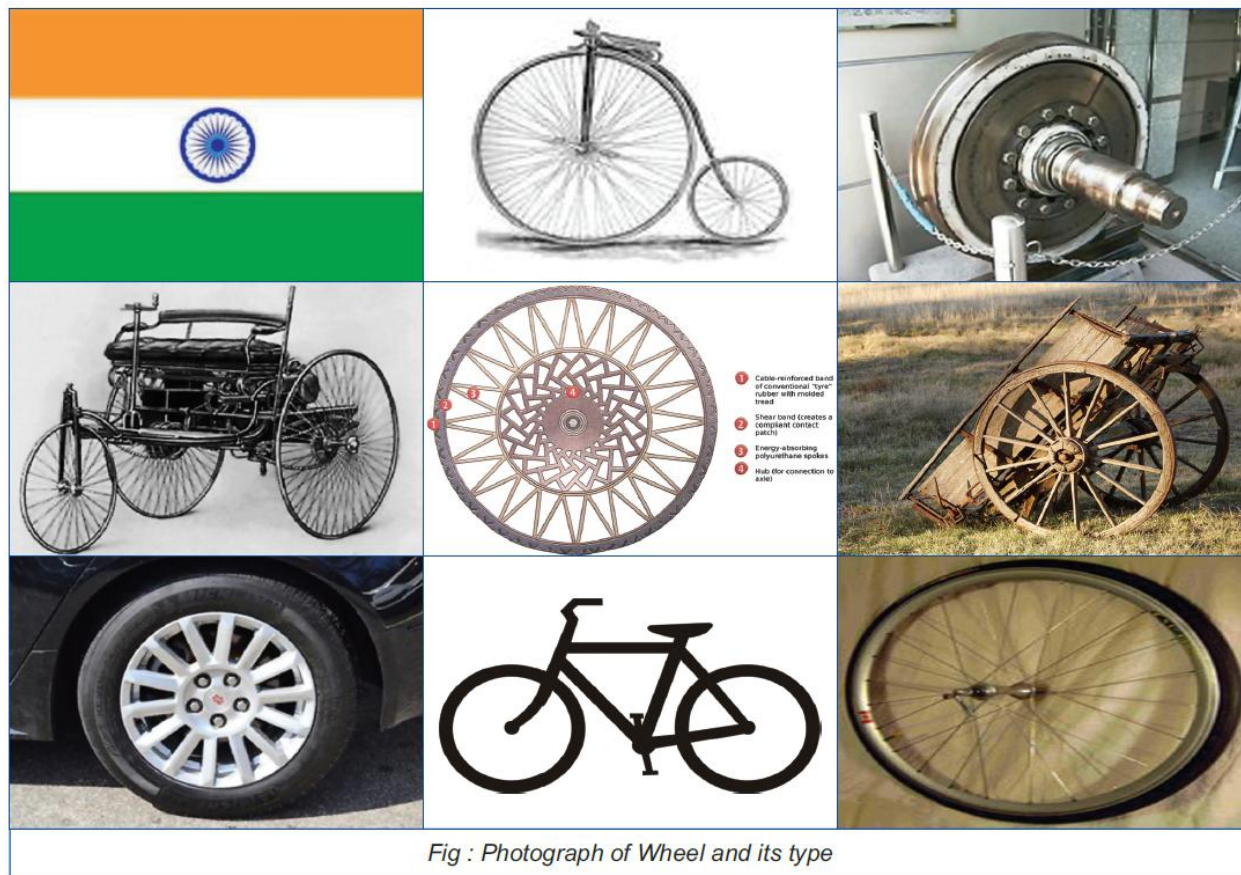

Wheel Cart

Wheel cart is a vehicle designed for transport, using two wheels. A handcart is pulled or pushed by one or more people. However, from history we learn that animals instead of men were used for pulling the cart. Animals can provide more power. Normally a cart was pulled by a pair of draught animals. The draught animals used for carts may be horses or ponies, mules, oxen, water buffalo or donkeys, or even smaller animals such as goats or large dogs.

Types of Carts

Larger carts may be drawn by animals, such as horses, mules, or oxen. They have been in continuous use since the invention of the wheel, in the 5th millennium BC. Carts may be named for the animal that pulls them, such as horse cart or oxcart. In modern times, horse carts are used in competitions. A dogcart, however, is usually a cart designed to carry hunting dogs: an open cart with two cross-seats back-to-back, the dogs could be penned between the rear-facing seat and the back end.



Fig.: Different types of cart

A bullock cart or ox cart is a two-wheeled vehicle pulled by oxen (draught cattle). It is a means of transportation used since ancient times in many parts of the world. They are still used today where modern vehicles are too expensive or the infrastructure does not favour them.

Carts are used especially for carrying goods. Bullock cart is pulled by one or two bullocks. The cart is attached to a bullock team by a special chain attached to yokes, but a rope may also be used for one or two animals. The driver and any other passengers sit on the front of the cart, while the load is placed at the back.

Development of Automobiles

Till now we have learnt how wheel was used in carts and horse powered carriages for transportation of goods and people. Engineers kept on improving the Horse Carriage design bit by bit. Parallely, man was working on a system that could be self-propelled, meaning that the system could be run without any man or animal force required for moving it.

In the year 1672 the very first such model was developed in the form of a toy. This was actually a steam engine. In this the power of steam was used to provide momentum to the toy.

Further improvements continued in various parts of the world. Then in the year 1806, the first cars powered by an internal combustion engine appeared. The fuel used for running this was 'fuel gas' instead of 'steam'. Of course, the process of using Fuel Gas is different than the process required for using Steam. Steam engine requires 'External combustion', whereas, fuel gas uses the principle of 'Internal Combustion'. We shall study this in detail later.

Meanwhile, engineers continued to improve designs till the year 1885 when the first modern gasoline- or petrol-fueled engine was developed in Europe. It is important to note that inventions in science and technology cannot often be used immediately by general public. One reason is that the cost of developing new technology is very high. Also, the first models usually do not have any comfort features. However, when more people demand the new models, the cost starts to come down. More features can also be added for making it attractive for general consumers.



Fig.: Cugnot Steam trolley
(Jonathan Holquinisbura)



Fig.: First practical car model

Karl Benz a brilliant German engineer designed and patented the first practical model in 1885. This model used internal combustion Engine and was called Motorwagen. Although, several other German engineers (including Gottlieb Daimler, Wilhelm Maybach and Siegfried Marcus) were working on the problem at about the same time, Karl Benz generally is acknowledged as the inventor of the modern automobile.



Fig: Photograph of the original Benz Patent Motorwagen, first built in 1885 and awarded the patent for the concept given here)

An automobile powered by his own four stroke cycle gasoline engine was built in Mannheim, Germany by Karl Benz in 1885 and granted a patent in January of the following year, under the auspices of his major company, Benz & Cie., which was founded in 1883. His first *Motorwagen* was built in 1885, and he was awarded the patent for its invention, basis his application on January 29, 1886. Benz began promotion of the vehicle on July 3, 1886, and about 25 Benz vehicles were sold between 1888 and 1893, when his first four-wheeler was introduced along with a model intended for affordability.

In August 1888 Bertha Benz, wife of Karl Benz, undertook the first road trip by car, to prove the roadworthiness of her husband's invention. During the last years of the nineteenth century, Benz was the largest automobile company in the world with 572 units produced in 1899.

Towards the end of 19th century, many automobile companies came up in Europe and America. They started producing different models. But these automobiles were very expensive and very few rich people could afford them like Kings, Queens and Rajas in India.

An average person could only dream but could not afford to own a car. Many attempts were being made in Europe and America for reducing costs. The large-scale, production-line manufacturing of affordable automobiles was started by Ransom Olds at his Oldsmobile factory in 1902. The assembly line style of mass production and interchangeable parts had been pioneered in the U.S. by Thomas Blanchard in 1821, at the Springfield Armory in Springfield, Massachusetts. This concept was greatly expanded by Henry Ford, beginning in 1914. With the introduction of this new manufacturing process, FORD Motor company launched the first large scale production of their Model T. In 1914, an assembly line worker could buy a Model T with four months' pay of some two hundred American car makers in existence in 1920.



Fig.: Car Ford Model T

In Europe much the same happened. Morris set up its production line at Cowley in 1924 and soon outsold Ford, while beginning in 1923 to follow Ford's practice of vertical integration. They bought Hotchkiss (engines), Wrigley (gearboxes), and Osberton (radiators), for instance, as well as competitors, such as Wolseley: in 1925, Morris had 41% of the total British car production. Most British small-car assemblers, from Abbey to Xtra had failed. Citroen did the same in France, coming to cars in 1919. Between them Renault's 10CV and Peugeot's 5CV, they produced 550,000 cars in 1925 and Mors, Hurtu, and others could not compete. Germany's first mass manufactured

car, the Opel 4PS *Laubfrosch* (Tree Frog), came off the line at Russelsheim in 1924, soon making Opel the top car builder in Germany, with 37.5% of the market.

Between the 1st and the 2nd World Wars a lot of attention of the Automobile industry went towards development of defense vehicles. As a result, several new vehicles like battle Tanks and Jeeps were developed. The tank became very popular in the war field. It is a very versatile vehicle, which can run in any road conditions i.e., in cross country terrain, hills, deserts and trenches etc.



Fig: 1926 Austin 7 Box

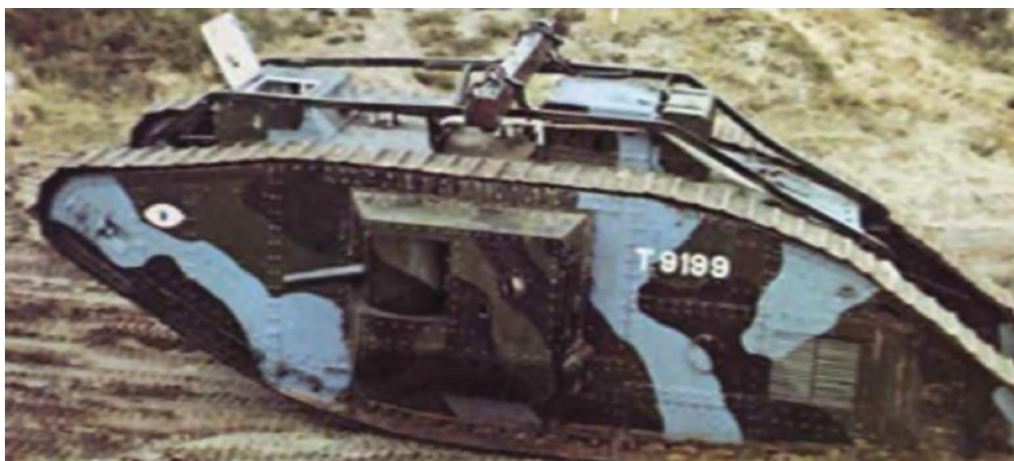

Fig: Mark V Tank

However, during this period, there were some very interesting designs in the passenger segment also. Volkswagen in Germany developed a car in the 30s, which looked like a crawling creature and was therefore called “Beetle” This model has the engine at the back and front bonnet was used as luggage compartment. The car was very convenient to drive and also good looking and stylish. It became very popular in Europe.



Fig: Jeweled one-millionth VW Beetle

Automobile Industry started on rapid modernization in the 50s and 60s. Many new models of cars were introduced like Edsel, Chevrolet etc.

In USA, road network was built after the second War. This road network was very modern with long highways stretching across the length and breadth of the country. It is good to note that USA has a very big land mass and vast geography. This allows open and wide roads to be built. On these roads models like the Beetle do appear very tiny!

The Big Three of the car industry namely General Motors, Ford & Chrysler set about to design big fast-moving cars for the American roads. Edsel, Buick, Pontiac Firebird, Chevrolet Impala etc. were some of the big cars that came on American highways in the 50s and 60s. It may also be noted that these models used large amounts of petrol or gasoline as it is called in US. But petrol consumption was not the main issue in those happy days. So, each car maker was competing with the other in making bigger & bigger designs with more luxuries added for comfort. All this made

owning and maintaining a car quite costly. Still, more and more Americans were buying these models. One very popular model from FORD was named 'MUSTANG'.

However, things changed after 1973. This was the year of the first "Oil Crisis". Petrol started becoming costlier as all the Arab nations got together in an alliance. Now, suddenly even Americans started looking for more economical designs.

Meanwhile, quietly but with determination, Japan was developing cars for marketing worldwide, mainly in the USA. Actually, after the devastation of their country during the WW II, several Japanese companies came into existence like Toyota, Mazda, Mitsubishi, Suzuki etc. Some of these like Mazda, were using American Technology. But these companies were also developing their own Research capabilities. As a result, when the 1973 oil crisis occurred, these companies were very well positioned to roll out smaller, compact, economical models in USA.

Since then, companies like Toyota, Honda have been steadily increasing their market presence worldwide. The modern era is normally defined as the 25 years before the current year. However, there are some technical and design aspects that differentiate modern cars from antiques. Without considering the future of the car, the modern era has been one of increasing standardization, platform sharing, and computer-aided design.

- 1966 – present Toyota Corolla – a simple small Japanese saloon/sedan that has come to be the best-selling car of all time.
- 1970 – present Range Rover – the first take on the combination of luxury and four-wheel drive utility, the original 'SUV'. Such was the popularity of the original Range Rover Classic, that a new model was not brought out until 1994.
- 1973 – present Mercedes-Benz S-Class – electronic Anti-lock Braking System, supplemental restraint airbags, seat belt pretensioners, and electronic traction control systems all made their debut on the S Class. These features would later become standard throughout the car industry.
- 1975 – present BMW 3 Series – the 3 Series has been on the Car and Driver magazine's annual Ten Best list 17 times, making it the longest running entry in the list.
- 1977– present Honda Accord saloon/sedan – this Japanese sedan became the most popular car in the United States in the 1990s, pushing the Ford Taurus aside, and setting the stage for today's upscale Asian sedans.
- 1981–1989 Dodge Aries and Plymouth Reliant – the "K-cars" that saved Chrysler as a major manufacturer. These models were some of the first successful American front-wheel drive, fuel-efficient compact cars.
- 1983 – present Chrysler minivans – the two-box minivan design nearly pushed the station wagon out of the market, and presaged today's crossover SUVs.
- 1984 – present Renault Espace – first mass one-volume car of noncommercial MPV class.
- 1986 – present Ford Taurus – this mid-sized front-wheel drive sedan with modern computer assisted design dominated the American market in the late 1980s, and created a design revolution in North America.
- 1989 –1999 Pontiac Trans Sport – was one the first of the one box cars.
- 1997 – present Toyota Prius – launched in the Japanese market, in September 2010 reached worldwide cumulative sales of 2.0 million units, becoming the most iconic hybrid electric vehicle in the world.
- 1998 – present Ford Focus – one of the most popular hatchbacks across the globe, that is also one of Ford's best-selling world cars.

- 2008 – present – Tata Nano – The Tata Nano is an inexpensive (100,000), rear-engine, four passenger city cars built by the Indian company Tata Motors and is aimed primarily at the Indian domestic market.
- 2010 – present, Nissan Leaf and Chevrolet Volt – an all-electric car and a plug-in hybrid correspondingly, were launched in the U.S. and Japanese markets in December 2010, becoming the first mass production vehicles of their kind.

Indian Automobile Scenario

We should now look at the Automobile industry in India. It started with import of cars for Royal families. Perhaps the first cars imported in India were in 1920s.

For many years India did not have any manufacturing capability of its own. Hindustan Motors is one of the original car manufacturers in India, founded in 1942

by Mr. B. M. Birla, it was a leader in car sales until the 1980s, when the industry was opened up from protection. It is the producer of the Ambassador car, widely used as a taxicab and as a government limousine. This car is based on the Morris Oxford, a British car that dates back to 1954.



Fig : Ambassador Car

Another India company Premier Automobiles was founded in 1944. The company first launched production by building vehicles under license from Dodge and Plymouth. In 1951, they began producing versions of the Fiat 500 for the Indian market. This was followed by the Fiat 1100 in 1954. In 1973, the 'Premier' was used on their vehicles for the first time the Premier President, based on the Fiat 1100 as Premier Padmini. Ambassador and Fiat/Padmini were the two dominant models of cars on the Indian roads till 1983. In 1983, Government of India started Maruti Udyog in collaboration with Suzuki of Japan. Maruti's first model called Maruti 800 became a big success. Within 5-6 years the company reached an annual production level of nearly 1,00,000 cars per year. They launched various models like 800, Gypsy, Omni van, Esteem, Zen, Bolero etc.



Fig : Fiat Car

By the end of 90s several other global multinational car makers also started manufacturing their models in India. Among them were, General Motors, Ford, Hyundai etc.



Fig : Maruti Car

In just a few years the Indian market for cars has become a hot spot of global automotive activity. As we see, Indian Auto industry started with import of cars in the 20s. Then the first manufacturing started in the 40s. With continued progress many Indian companies like Maruti, Tata, Mahindra have become very big global names. Now, they are not merely manufacturing to European/American or Japanese designs. But they are doing so with their own research & development capabilities. As a result, Nano model was developed by TATA

Motors. This is the cheapest car in the world with all convenient and quality features. India is now also exporting nearly 12% of manufactured cars to Europe, USA and elsewhere in the world.

The automotive industry in India is one of the largest in the world and one of the fastest growing globally. India's passenger car and commercial vehicle manufacturing industry is the sixth largest in the world, with an annual production of more than 3.7 million units in 2010. According to recent reports, India is set to overtake Brazil to become the sixth largest passenger vehicle producer in the world, growing 16-18 per cent to sell around three million units in the course of 2011-12. In 2009, India emerged as Asia's fourth largest exporter of passenger cars, after Japan, South Korea, and Thailand. In 2010, India became Asia's third largest exporter of passenger cars, after Japan and South Korea beating Thailand.

As on 2010, India is home to 40 million passenger vehicles. More than 3.7 million automotive vehicles were produced in India in 2010 (an increase of 33.9%), making the country the second fastest growing automobile market in the world. According to the Society of Indian Automobile Manufacturers, annual vehicle sales are projected to increase to 5 million by 2015 and more than 9 million by 2020. By 2050, the country is expected to top the world in car volumes with approximately 611 million vehicles on the nation's roads.

The majority of India's car manufacturing industry is based around three clusters in the south, west and north. The southern cluster near Chennai is the biggest with 40% of the revenue share. The western hub near Maharashtra is 33% of the market. The northern cluster is primarily Haryana with 32%. Chennai, is also referred to as the "*Detroit of India*" with the India operations of Ford, Hyundai, Renault and Nissan headquartered in the city and BMW having an assembly plant on the outskirts.

Chennai accounts for 60% of the country's automotive exports. Gurgaon and Manesar in Haryana form the northern cluster where the country's largest car manufacturer, Maruti Suzuki, is based. The Chakan corridor near Pune, Maharashtra is the western cluster with companies like General Motors, Volkswagen, Skoda, Mahindra and Mahindra, Tata Motors, Mercedes Benz, Land Rover, Fiat and Force Motors having assembly plants in the area. Aurangabad with Audi, Skoda and Volkswagen also forms part of the western cluster. Another emerging cluster is in the state of Gujarat with manufacturing facility of General Motors in Halol and further planned for Tata Nano at Sanand. Ford, Maruti Suzuki and Peugeot-Citroen plants are also set to come up in Gujarat. Kolkata with Hindustan Motors, Noida with Honda and Bangalore with Toyota are some of the other automotive manufacturing regions around the country.

Session II: Classification of Vehicles and Structure

Introduction

The Automotive industry in India is one of the largest in the world and one of the fastest growing globally. India's Passenger Car and Commercial Vehicle manufacturing industry is the seventh largest in the world, with an annual production of more than million units in 2011.

The Automobile segment comprises of the following four broad categories of vehicles:

- Two-Wheelers and Three-Wheelers
- Passenger Vehicles
- Commercial Vehicles
- Special Application Vehicles

Automobiles Categories

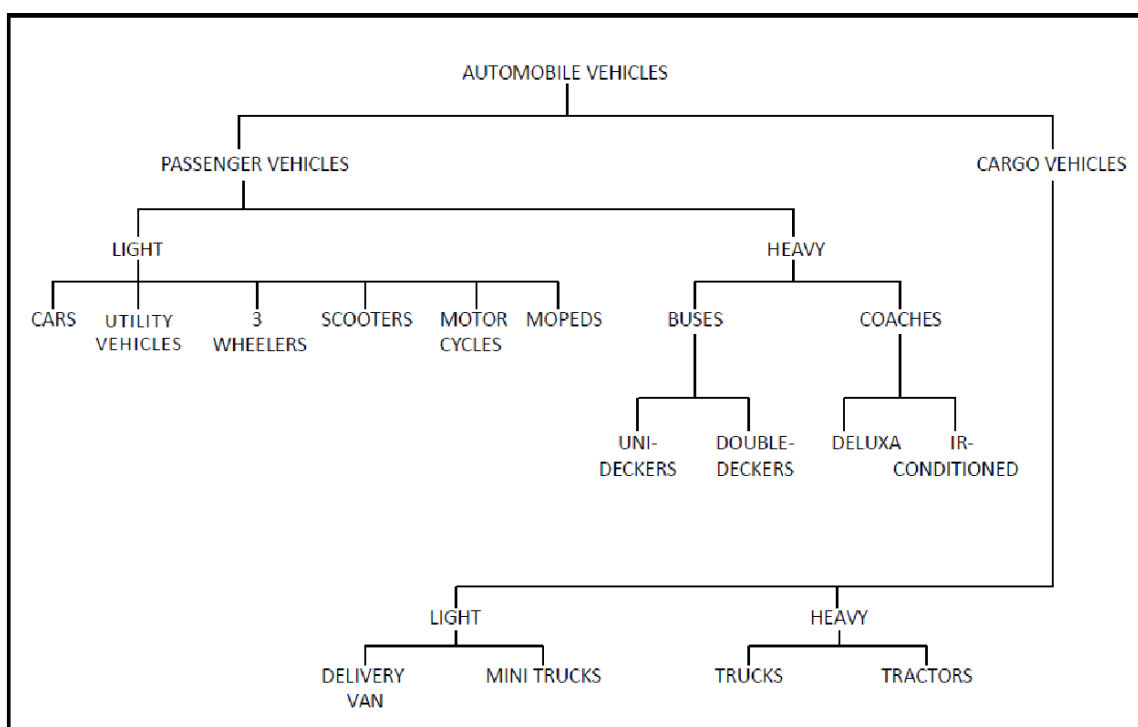

Classification of Automobiles

Automobiles are classified by purpose (passenger/goods), fuel type (petrol, diesel, electric, hybrid), size, and capacity (light/heavy), or number of wheels (2, 3, 4, multi-axle). Major categories include Passenger Vehicles (cars, buses) and Commercial Vehicles (trucks, lorries). Common body types include Hatchbacks, Sedans, SUVs (Sport Utility Vehicle), and MPVs (Multi-Purpose Vehicle).

Key Classifications of Automobiles:

- **Based on Purpose & Load:**
 - **Passenger Vehicles:** Designed for carrying people, such as cars, passenger vans, and buses.

- **Goods Vehicles:** Designed for transporting goods, including lorries, trucks, and delivery vans.
- **Special Purpose Vehicles:** Designed for specialized tasks like ambulances, fire engines, and military vehicles.
- **Heavy Duty Vehicles (HDV):** Large, powerful, high-capacity vehicles like trucks and buses.
- **Light Duty Vehicles (LDV):** Smaller vehicles for personal or light transport, including cars, scooters, and motorcycles.
- **Based on Body Shape/Design (Cars):**
 - **Hatchback:** Compact with a rear door that opens upwards (e.g., Alto, Swift).
 - **Sedan (Three-box):** Separate compartments for engine, passengers, and luggage (e.g., City, Dzire).
 - **SUV (Sports Utility Vehicle):** High ground clearance, large tires, and rugged design (e.g., Pajero, Safari).
 - **MPV (Multi-Purpose Vehicle/Minivan):** High roof, reconfigurable seating for passengers.
 - **Convertible:** Vehicle with a foldable or removable roof.
- **Based on Fuel Type:**
 - **Internal Combustion (IC) Engine:** Uses petrol, diesel, CNG & LPG also.
 - **Electric Vehicles (EV):** Powered by batteries and electric motors.
 - **Hybrid Vehicles:** Combine an IC engine with an electric motor.
 - **Alternative Fuel:** Uses Compressed Natural Gas (CNG), Liquefied Petroleum Gas (LPG), or Hydrogen.
- **Based on Drive Configuration:**
 - **Front-Wheel Drive (FWD):** Power delivered to front wheels.
 - **Rear-Wheel Drive (RWD):** Power delivered to rear wheels.
 - **All-Wheel/Four-Wheel Drive (AWD/4WD):** Power delivered to all wheels for better traction.
- **Based on Number of Wheels:**
 - **Two-wheelers:** Scooters, motorcycles.
 - **Three-wheelers:** Auto-rickshaws, tempos.
 - **Four-wheelers:** Cars, jeeps, trucks.
 - **Multi-axle:** Large trucks and trailers.

Various Types of Automobiles

The Automobile segment comprises of the following four broad categories of vehicles:

- Two-Wheelers and Three-Wheelers
- Passenger Vehicles
- Commercial Vehicles
- Special Application Vehicles

Two-Wheelers, being the most popular means of personal transport, account for about 75% of the total automobile production in India, while Passenger Vehicles account for nearly 16% of the production. However, owing to their lower price. Two wheelers account for only around 32% of the sales in terms of value, while Passenger Vehicles account for around 62% of sales.

TWO WHEELERS AND THREE WHEELERS

Two Wheelers

India is the largest producer of two-wheelers in the world. In the last few years, the Indian two-wheeler industry has seen spectacular growth. The country stands next to China and Japan in terms of production and sales respectively.

Majority of Indians, especially the youngsters, prefer motorbikes rather than cars. Capturing a large share in the two-wheeler industry, bikes and scooters cover a major segment. Bikes are considered to be the favourite among the youth as they help in easy commutation and also look stylish. Large variety of two wheelers are available in the market, known for their latest technology and enhanced mileage. Indian bikes, scooters and mopeds represent style and class for both men and women in India.

Benefits of Two Wheelers

Two-wheelers are the most popular and highly sought out medium of transport in India. The trend of owning Two-Wheelers is due to their:

- Economical price
- Fuel-efficiency
- Comfort level

However, some Indian bike enthusiasts prefer high performance imported bikes. Some of the most popular high-speed bikes are Royal Enfield, Suzuki Hayabusa, Kawasaki Ninja, Suzuki Zeus and Honda Unicorn. These super bikes are specially designed for those who have a zeal for power and speed. We can conclude that a motorcycle is a motor-powered two-wheeler, similar in construction with bicycles.

Identification of Two-Wheeler:

You must have seen various types of two wheelers in your area or on the roads. Every Two - wheeler has a sticker of its model type and name of the manufacturer. You can identify the make of the Two-Wheeler by the sticker/logo fixed on body. Popular brands of Two-Wheeler manufacturers are Hero, Honda, Bajaj, TVS, Suzuki. Two-Wheeler manufacturers produce different models as per given specification. Some of famous models are given below:

Hero make - Impulse, Splendor, CDdawn, Pleasure, Passion Plus

Bajaj make - Pulsar , Discover, Platina

TVS make - Apache, Star, Scooty streak, Scooty Pep, Star City

Honda make - Activa, Dio, aviator

Suzuki make - Access, Intruder M800, Zeus

These models vary by size, weight, dimension type size, engine capacity.



Three Wheelers

A Three-Wheeler is a vehicle with three wheels. Auto rickshaws (often called just auto) are common all over India, and provide cheap and efficient transportation. New auto rickshaws run on CNG and are environmentally friendly. Typical mileage for an Indian-made auto rickshaw is around 35 kilometers per liter of petrol. Many major nationalized banks in India offer loans to self-employed individuals seeking to buy auto rickshaws. Auto rickshaw manufacturers in India include Bajaj Auto, Kumar Motors, Kerala Auto Limited, Force Motors (previously *Bajaj Tempo*), Mahindra & Mahindra, Piaggio Ape and TVS Motors. Auto rickshaws are found in cities, villages and in the countryside.

There are two types of auto rickshaws in India. In older versions the engines were situated below driver's seat. In newer versions engines are in rear portion. They normally run on petrol, diesel, CNG and electricity stored in battery. The seating capacity of a normal rickshaw is 4, including the driver. There are also six seated rickshaws in parts of Maharashtra. In cities and towns across India it is the backbone of city transport. Normally their fare rates are controlled by govt. They have traffic meters.

Many three-wheelers which exist in the form of motorcycle-based machines are called trikes and often have the front single wheel and mechanics similar to that of a motorcycle and the rear axle similar to that of a car. Sometimes such vehicles are owner-constructed using a portion of a rear engine, rear-drive Volkswagen Beetle in combination with a motorcycle front end.

Other trikes include ATVs that are specially constructed for off road use. Three-wheeled automobiles can have either one wheel at the back and two at the front, (for example: Morgan Motor Company) or one wheel at the front and two at the back (such as the Reliant Robin).



PASSENGER VEHICLES AND COMMERCIAL VEHICLES

Passenger Vehicles

Passenger vehicle refers to a machine that can carry a person or a group of persons. There are several types of passenger vehicles like cars/jeeps/tempo etc. you must have seen various models of passenger vehicles in your village, town or city. You must have also travelled in these passenger vehicles.

Some of the popular model of cars, buses, jeep, and tempo are illustrated below:

Car: A motor car or car is a wheeled motor vehicle used for transporting passengers, which also carries its own engine or motor. Various popular cars in India are Maruti Suzuki, Tata motor, Hyundai etc. Now a days various car manufacturers of International level have established in our country.



Fig : Important passenger vehicle used in our country

Jeep: Jeep was first produced by Willys Overland. Jeep celebrated its 70th anniversary in 2011 and it is the oldest off road vehicle and SUV in the world. Jeep is a brand of Chrysler. Jeep is mainly used for its excellent off road capabilities. Jeep was primarily designed and constructed to aid military requirements. Slowly changes were made and the company started producing civilian models. It has gone through various changes under different leaderships. It is part of Chrysler Group LLC which is now part of FIAT Italy. Jeep is found in many countries around the world. The models in Jeep range are Jeep Grand Cherokee, Jeep Patriot, Jeep Compass, Jeep Liberty, Jeep Commander and Jeep Wrangler.

Commercial Vehicles

A Commercial Vehicle is a type of motor vehicle that may be used for transporting of goods as well passengers. Commercial vehicles influence the trade, commerce and industry of a country in a major way. Vehicles falling under this category are mainly buses & trucks. It comes in various uses such as transportation of goods, shipping and handling of various commodities and so on. The future of companies manufacturing these vehicles is very bright due to India's growing commercial sector. The export of commercial vehicles has gone up considerably breaking all previous records.

Trucks are basically used for carrying goods and materials in bulk. These trucks are classified into sub-categories depending on their size and functional use: haulage, rigid trucks, tippers, cabs, delivery vans and trailers. The fuel efficiency of these vehicles has also improved to a great extent in the past few years. The major players of truck manufacturers in India are Ashok Leyland, Eicher, Tata Motors and Swaraj Mazda.

A Bus is a huge commercial vehicle, said to have originated in France in the year 1826 designed by Stanislas Baudry under the name of 'Omnibus'. The basic purpose of this vehicle is to carry the passengers as it is an easy and cost-effective medium of transport.

The major producers of buses in India are Ashok Leyland and Tata Motors, Swaraj Mazda, Volvo and Eicher have made a big name in manufacturing mini-buses. However, there are huge subcategories of buses like Commuter Bus, School buses, Electric buses and so on. In India, CNG buses have occupied a huge market thus making it fuel efficient and environmentally friendly vehicle.



Fig : Photograph of CNG Buses

AGRICULTURAL VEHICLES

You must have seen tractors in your area. Do you know the meaning of tractor? It can be said that a tractor is an engineering vehicle specifically designed to deliver a high attractive effort (or

torque) at slow speeds, for the purposes of hauling a trailer or machinery used in agriculture or construction. Most commonly, the term is used to describe a farm vehicle that provides the power and traction to mechanize agricultural tasks, especially (and originally) till age, but nowadays a great variety of tasks. Agricultural implements may be towed behind or mounted on the tractor, and the tractor, may also provide a source of power if the implement is mechanised.



The word tractor was taken from Latin, being the agent noun of *trahere* "to pull". The first recorded use of the word meaning "an engine or vehicle for pulling wagons or ploughs" occurred in 1901, displacing the earlier term "traction engine" (1859). Tractors are heavy vehicles serving the purpose of hauling at an extremely low speed. India being one of the major agricultural country, makes the use of tractors on a large scale. It is one of the heaviest vehicle, basically used for carrying out the agricultural tasks in an effective way.

Modern tractors usually employ diesel engines which deliver 18 to 575 horsepower. The major producers of tractors in India are Mahindra, Eicher, TAFE, Sonalika, Ashok Leyland, Escorts, Force Motors and Swaraj Enterprise. The most common use of the term "tractor" is for the vehicles used on farms. The farm tractor is used for pulling or pushing agricultural machinery or trailers, for plowing, tilling, disking, harrowing, planting and similar tasks. A variety of specialty farm tractors have been developed for particular uses. These include row crop tractors with adjustable tread width to allow the tractor to pass down rows of corn, tomatoes or other crops. Many utility tractors are used for non-farm grading, landscape maintenance and excavation purposes, particularly with loaders, backhoes, pallet forks and similar devices. Small garden or lawn tractors designed for suburban and semirural gardening and landscape maintenance also exist in a variety of configurations.

The durability and engine power of tractors make them very suitable for engineering tasks. Tractors can be fitted with engineering tools such as dozer blades, buckets, hoes, rippers, etc. The most common attachments for the front of a tractor are dozer blades or buckets. When attached to engineering tools, the tractor is called an engineering vehicle.

Combine Harvester: The combine harvester, or simply combine, is a machine that harvests grain crops. The name derives from the fact that it combines three separate operations, reaping, threshing, and winnowing, into a single process. Among the crops harvested with a combine are wheat, oats, rye, barley, corn (maize), soybeans and flax (linseed). The waste straw left behind on the field is the remaining dried stems and leaves of the crop with limited nutrients which is either chopped and spread on the field or baled for feed and bedding for livestock.



Combine harvesters are one of the most economically important labor saving inventions, enabling a small fraction of the population to be engaged in agriculture.

 4LL-200
Combine Harvester



CONSTRUCTION EQUIPMENT VEHICLES

Lot of new roads, houses and plants are being built these days. You must have seen big machines that reach the construction site to dig earth. These are Special Purpose Automobiles and are sometime called Earth Moving Equipment.

There are several types of earthmoving or construction equipment such as:

- Dumpers
- Dozers
- Road rollers
- Tillers
- Excavators

As their various names suggest they are used for various types of work like digging or excavating earth and dumping it at a designated place. Road rollers are used for leveling roads.

Bulldozer: A bulldozer is a crawler (continuous tracked tractor) equipped with a substantial metal plate (known as a blade) used to push large quantities of soil, sand, rubble, or other such material

during construction or conversion work and typically equipped at the rear with a claw-like device (known as a ripper) to loosen densely-compacted materials.

Bulldozers can be found on a wide range of sites, mines and quarries, military bases, heavy industry factories, engineering projects and farms. The term "bulldozer" is often used erroneously to mean any heavy equipment (sometimes a loader and sometimes an excavator), but precisely, the term refers only to a tractor (usually tracked) fitted with a dozer blade. Most often, bulldozers are large and powerful tracked heavy equipment. The tracks give them excellent ground hold and mobility through very rough terrain. Wide tracks help distribute the bulldozer's weight over a large area (decreasing pressure), thus preventing it from sinking in sandy or muddy ground. Extra wide tracks are known as 'swamp tracks'.



Bulldozers have excellent ground hold and a *torque divider* designed to convert the engine's power into improved dragging ability. The Caterpillar D9, for example, can easily tow tanks that weigh more than 70 tons. Because of these attributes, bulldozers are used to clear areas of obstacles, shrubbery, burnt vehicles, and remains of structures. The bulldozer's primary tools are the blade and the ripper.

Road Roller: A road roller (sometimes called a *roller-compactor*, or just *roller*) is a compactor type engineering vehicle used to compact soil, gravel, concrete, or asphalt in the construction of roads and foundations. Similar rollers are used also at landfills or in agriculture. In some parts of the world, road rollers are still known colloquially as steam rollers, regardless of their method of propulsion.



This typically only applies to the largest examples (used for road-making). Road rollers use the weight of the vehicle to compress the surface being rolled (static) or use mechanical advantage (vibrating). Initial compaction of the substrate on a road project is done using a pad foot drum roller, which achieves higher compaction density due to the pads having less surface area. On large freeways a four-wheel compactor with padfoot drum and a blade, such as a Caterpillar 815/825 series machine, would be used due to its high weight, speed and the powerful pushing force to spread bulk material.

Dumper: Dumper is a vehicle designed for carrying bulk material, often on building sites. Dumpers are distinguished from dump trucks by configuration. A Dumper is usually an open 4-wheeled vehicle with the load skip in front of the driver, while a Dump Truck has its cab in front of the load. The skip can tip to dump the load, this is where the name "dumper" comes from.

They are normally diesel powered. A towing eye is fitted for secondary use as a site tractor. Dumpers with rubber tracks are used in special circumstances and are popular in some countries. Modern dumpers have payloads of up to 10 tonnes (11 short tons, 9.8 long tons) and usually steer by articulating at the middle of the chassis (pivot steering). They have multi-cylinder diesel

engines, some turbocharged, electric start and hydraulics for tipping and steering and are more expensive to make and operate.



Session III: Indian Automobile Market and Prominent Automobile Manufacturers in India

Introduction

The Automotive Industry consists of different organizations and companies with a critical objective of vehicle designing, developing, marketing, manufacturing, selling and providing services. The automotive industry is a vital part of the world's economic sectors as it generates revenue contributing to Nations GDP (Gross Domestic Product). The industry main bodies are SIAM (Society of Indian Automobile Manufacturers), ACMA (Automotive Component Manufacturers Association), and FADA (Federation of Automobile Dealers Associations).

Like every business, automobiles have a value chain which is very important for the business to succeed. The value chain covers all the activities starting from the conception of the product to the final delivery in the hands of a customer. In cases where the company involved deals with the production of goods, their value chain commences from the acquisition of raw materials. The processes in the value chain add value to the product until its ready for sale. Analysis of the value chain helps in analyzing and identifying where problems are to make improvements and increase the efficiency of the operations. A compelling value chain analysis would also assist in generating a competitive advantage.

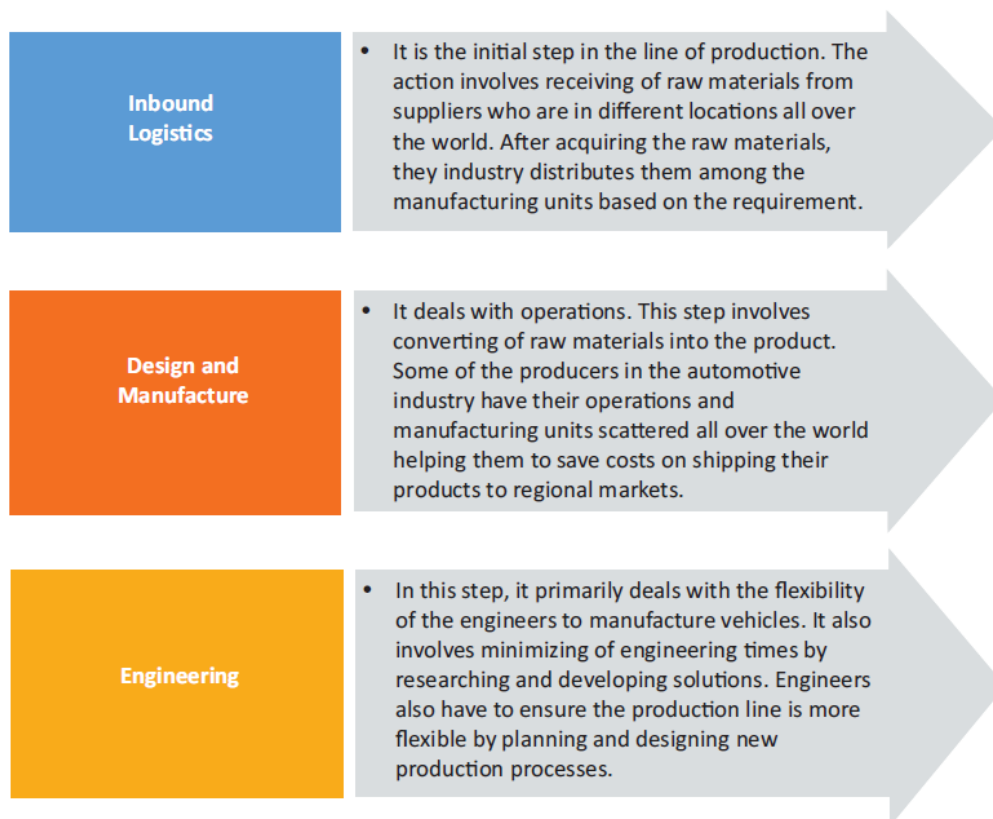

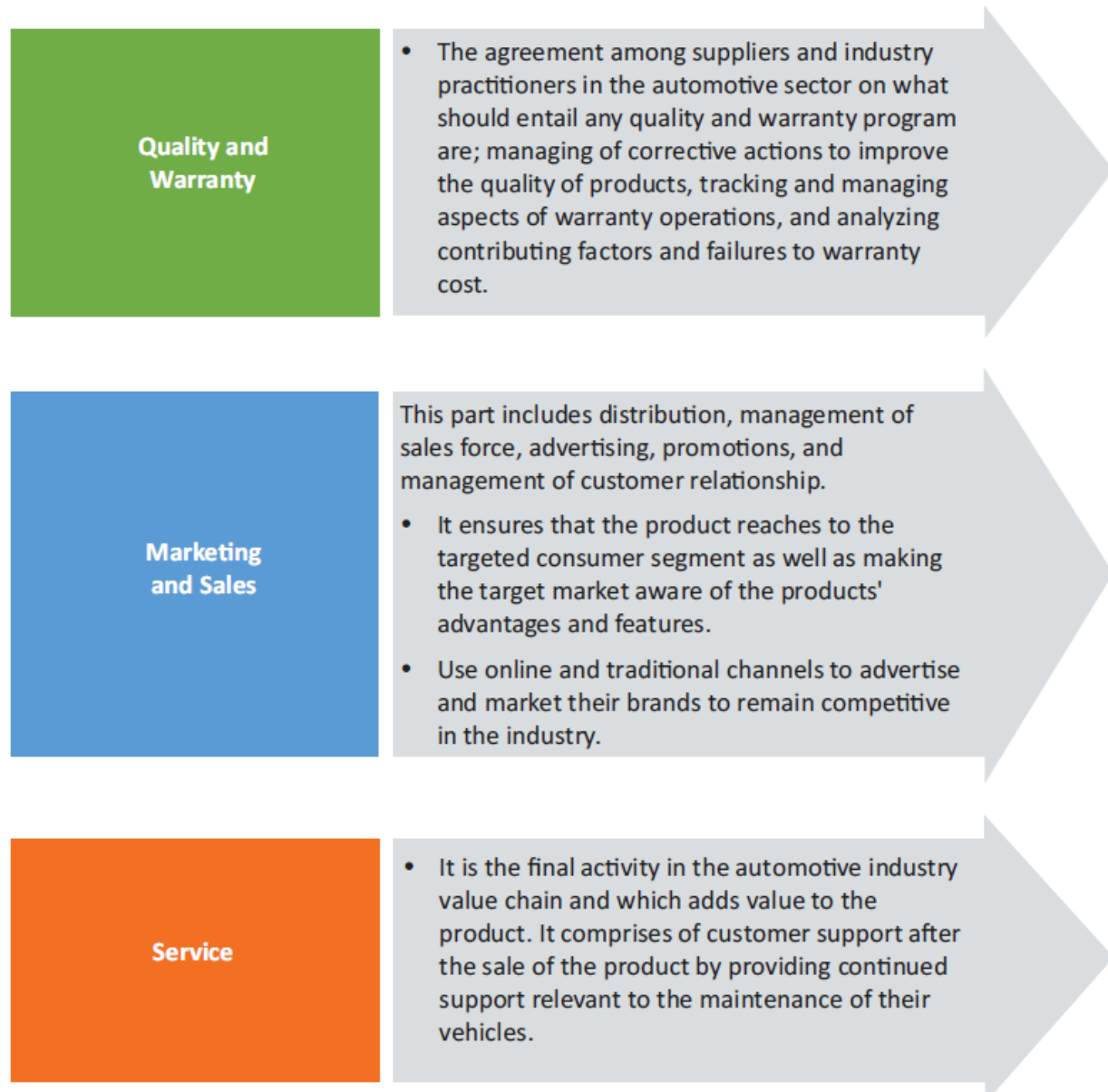

Indian Automobile Industry

India's auto industry is a global powerhouse, ranking among the top 4 producers worldwide, a major economic contributor (7.1% of GDP), a significant job creator, and a leader in 2 & 3-wheelers, driving economic growth, green mobility, and exports with strong domestic demand for SUVs/UVs and increasing EV adoption. It's a diverse ecosystem covering all vehicle types, leveraging "Make in India," skilled labor, and growing consumerism, aiming to become a global manufacturing hub.

Key Aspects & Stats (2023-2025)

- **Global Rank:** 4th largest producer, #1 in Two and Three wheelers,.
- **Economic Contribution:** ~7.1% to India's GDP, ~49% to manufacturing GDP.

- **Turnover:** ~\$240 billion (₹20 Lakh Crore).
- **Employment:** Supports ~30 million direct & indirect jobs.
- **Exports:** ~\$35 billion in vehicles & components.

Segments & Strengths

- **Diverse Segments:** Covers 2/3-wheelers, Passenger Vehicles (PVs), Commercial Vehicles (CVs), tractors, and emerging EVs.
- **SUV Boom:** Utility Vehicles (UVs) & SUVs are major growth drivers.
- **EV Growth:** Strong government push boosting Electric Vehicle (EV) sales.
- **Components:** Growing auto component sector, significant export potential.
- **Tractors:** World's largest tractor market (excluding sub-20 HP).

Drivers & Future

- **Economic Growth:** Rising incomes & strong domestic demand fuel expansion.
- **Policy Support:** "Make in India" & "Green Mobility" initiatives boost manufacturing & EVs.
- **Manufacturing Hub:** Cost-competitive workforce & established ecosystem position India as a global auto hub.
- **Future Outlook:** Projected to grow significantly, aiming for ₹15 lakh crore turnover by 2030.

OEMs in the Automobile Sector

The Original Equipment Manufacturers referred to as the OEMs are the vehicle producers that manufacture and assemble automobiles. For e.g. passenger cars, utility vehicles, commercial vehicles, two-wheelers, three-wheelers etc. There are also companies in India of domestic and foreign origin that compete for the market share in an oligopolistic market for automobiles in the economy. The OEMs compete with each other based on economies of scale, technology, quality, and cost of production to gain market share in the industry. Technology is the main aspect of competition for any OEMs as it reduces the cost of production and enhances labour and capital productivity. The main players are listed along with the category to which they belong.



Light/ Passenger Vehicles

Maruti Suzuki, Tata Motors, Force Motors, Mahindra and Mahindra and Hindustan Motors of the Indian origin and Volkswagen, Toyota, Nissan, Hyundai, Honda, Chrysler, Fiat, General Motors, Ford and BMW are of the foreign origin.

Commercial Vehicles Trucks and Buses

Tata Motors, Ashok Leyland, Mahindra and Mahindra, Eicher Motors, Force Motors and Swaraj Mazda of the Indian origin and Volvo of the foreign origin.



Commercial Vehicles: Construction and Agriculture

Bharat Earth Movers , CASE New Holland Construction Equipment ,Caterpillar India, Escorts Construction Equipment , JCB , Kobelco Construction Equipment , Komatsu , Tata-Hitachi Construction , Terex India , Volvo India

Three Wheelers

Piaggio, Mahindra and Mahindra, Bajaj Auto, Force Motors, Atul Auto, Scooters India, and TVS



Two Wheelers

Hero Motocorp, Bajaj Auto, TVS, Mahindra and Mahindra of the Indian origin and Royal Enfield, Vespa Scooters, Yamaha, Suzuki and Honda of the foreign origin

Electric Vehicles (EV)

Tata Motors, Mahindra & Mahindra, Ola Electric, Ather Energy, Hero MotoCorp, TVS Motor Company, Bajaj Auto, and Hyundai



Changing Trends in the Indian Automobile Sector

Currently, India's automotive industry is at an inflection point and is witnessing five megatrends that are expected to transform the industry in a big way. Rapidly evolving customer needs, the disruptive impact of technology, the dynamic regulatory environment, changing mobility patterns, and global interconnectedness are all impacting the way auto companies are doing business. The industry has never witnessed this magnitude of multi-dimensional change till now.

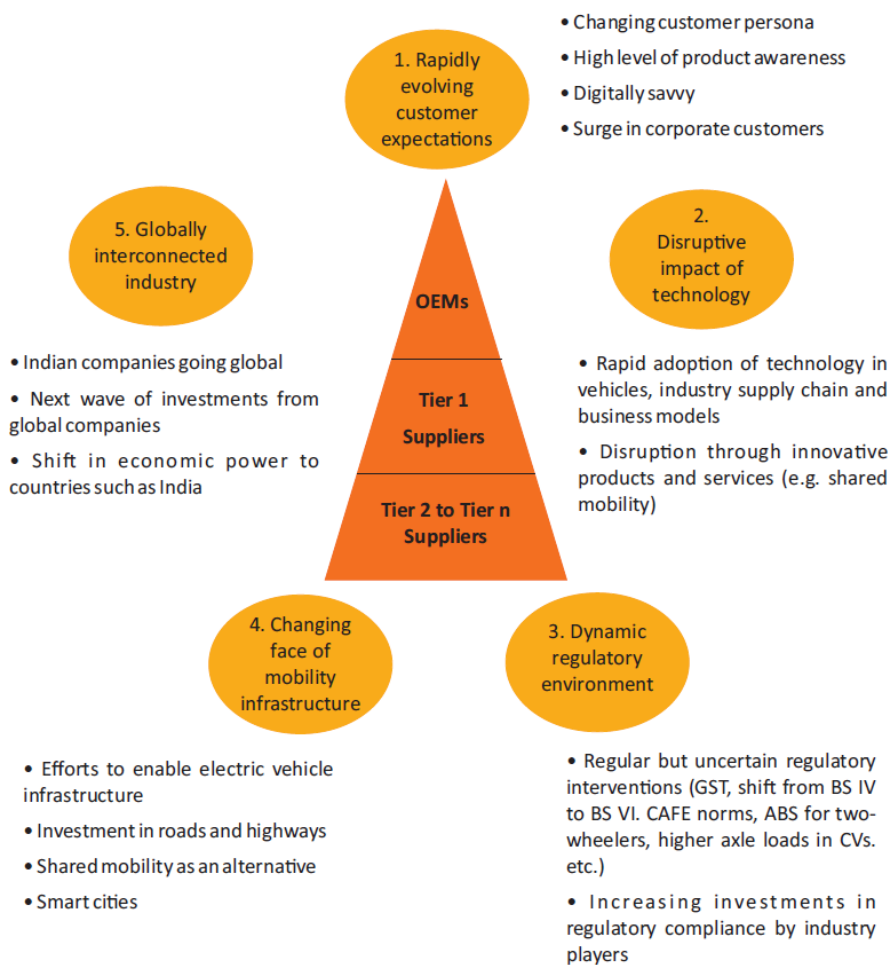

Unit II

Introduction to Automobile Dealership and Role of Sales & Service Personnel

Session I: Sub-sectors of Automotive Industry & Automotive Dealership Structure

Sub sectors of Automobile Industry

The automobile industry is a complex, multi-layered sector that acts as a major economic driver, contributing significantly to global manufacturing and GDP. It involves a vast ecosystem from initial design to post-sale services.

Here are the sub-sectors of the automobile industry and their functions:

1. Research & Development (R&D)

- **Focus:** Engineering, design, and testing.
- **Functions:**
 - **Product Development:** Designing new vehicle models, enhancing engine efficiency, and developing advanced electric vehicle (EV) batteries.
 - **Technology Advancement:** Developing Autonomous Driver Assistance Systems (ADAS), connected car features (IoT), and lightweight materials.
 - **Testing and Validation:** Conducting simulations and physical crash tests for safety and environmental regulations.
 - **Software-Defined Vehicles:** Focusing on AI, software engineering, and Over-the-Air (OTA) updates.

2. Manufacturing (OEMs and Components)

- **Focus:** Production and assembly.
- **Functions:**
 - **Original Equipment Manufacturers (OEMs):** Assembling finished vehicles (cars, two-wheelers, commercial vehicles).
 - **Component Manufacturers (Tier 1 & 2):** Producing engine parts, drive transmissions, steering systems, braking parts, and bodies.
 - **Supply Chain Management:** Coordinating the just-in-time delivery of parts to assembly lines.
 - **Quality Control:** Ensuring adherence to stringent safety and quality standards.

3. Sales and Marketing

- **Focus:** Distribution and retail.
- **Functions:**
 - **Dealership Management:** Showcasing and selling new/pre-owned vehicles through authorized dealers.

- **Marketing and Branding:** Creating brand awareness and running campaigns to attract customers.
- **Customer Relationship Management (CRM):** Managing leads, conducting test drives, and handling the purchasing process.
- **Digitalization:** Enabling online sales and virtual showrooms.

4. Service and Maintenance (After-Sales)

- **Focus:** Post-sale support.
- **Functions:**
 - **Vehicle Maintenance:** Providing routine servicing, repairs, and diagnostics.
 - **Spare Parts & Accessories:** Supplying genuine parts to maintain vehicle performance.
 - **Warranty Services:** Fulfilling manufacturer warranty requirements.

5. Road Transport and Logistics

- **Focus:** Mobility and distribution.
- **Functions:**
 - **Fleet Operations:** Managing large fleets for commercial cargo or passenger transport.
 - **Logistics:** Transporting finished vehicles from factories to dealerships.
 - **Infrastructure Support:** Developing charging networks for electric vehicles.

6. Finance and Insurance

- **Focus:** Financial facilitation.
- **Functions:**
 - **Vehicle Financing:** Providing loans to consumers and dealers for purchasing or leasing vehicles.
 - **Insurance Services:** Offering mandatory and voluntary insurance policies to cover vehicle damage, theft, and third-party liability.
 - **Dealer Financing:** Offering inventory financing to support the supply chain.

Dealership Structure

The structure of a modern automotive dealership is traditionally divided into two main categories: **Front-End Operations** (Sales and Finance) and **Back-End Operations** (Service and Parts). These departments are increasingly unified by a single digital "backbone" or Dealer Management System (DMS) to improve data flow and customer experience.

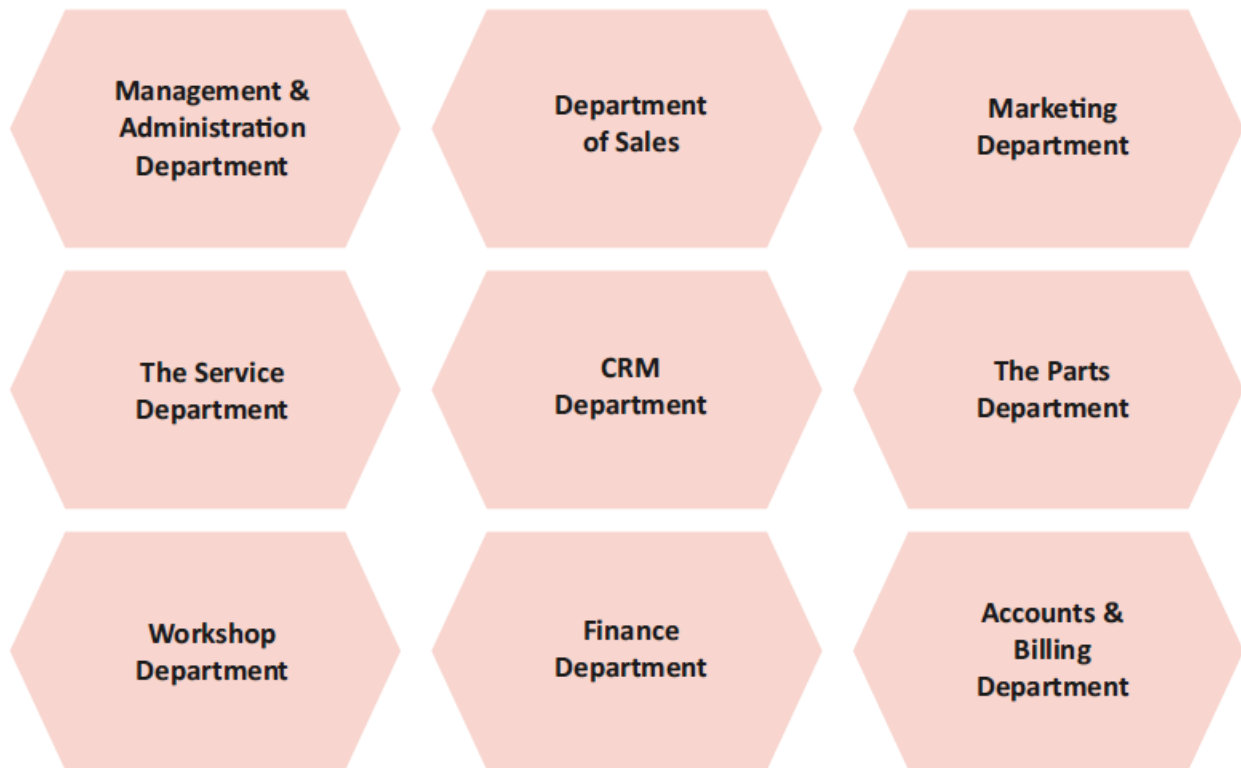

1. Front-End Operations (Sales & Finance)

This is the revenue-generating side of the business focused on vehicle acquisition and movement.

- **New Vehicle Sales:** Focuses on current model year inventory.
- **Pre-Owned (Used) Sales:** Handles trade-ins and used inventory; often includes a **Certified Pre-Owned (CPO)** specialist.
- **Finance & Insurance (F&I):** The department where customers finalize the purchase. They manage loans, credit applications, and sell "backend products" like extended warranties, gap insurance, and maintenance plans.
- **Business Development Center (BDC):** The digital hub of the dealership. BDC agents handle internet leads, phone inquiries, and schedule appointments for the sales floor.

2. Back-End Operations (Fixed Ops)

"Fixed Operations" refers to parts and service. This department is often the most consistent profit driver for a dealership.

- **Service Department:**
 - **Service Advisors:** The primary point of contact for customers.
 - **Technicians (Mechanics):** Categorized by skill level (Lube Techs, Line Techs, and Master Techs).

- **Warranty Administrator:** Manages claims between the dealership and the manufacturer.
- **Parts Department:**
 - **Retail Counter:** Sells parts directly to customers.
 - **Wholesale/Service Counter:** Supplies parts to the dealership's own service bay and local independent repair shops.
 - **Inventory Control:** Manages stock levels and emergency orders.

3. Administrative & Executive Leadership

This tier ensures legal compliance, financial health, and overall strategic direction.

Role	Responsibility
Dealer Principal	The owner or primary stakeholder of the franchise.
General Manager (GM)	Oversees all departments; responsible for the entire P&L (Profit & Loss).
General Sales Manager (GSM)	Coordinates between New, Used, and F&I departments.
Office Manager / Controller	Manages accounting, payroll, and manufacturer financial statements.
Compliance Officer	Ensures the dealership follows privacy laws, safety standards, and advertising regulations.

Job roles at dealership and their duties

1. Sales Department

- **Sales Consultant / Executive:** Engages with customers, provides test drives, explains vehicle features, negotiates pricing, and manages documentation.
- **Finance & Insurance (F&I) Manager:** Often handles the final paperwork, financing options, and extended warranty sales.

2. Service & Parts Department

- **Service Advisor:** Acts as the primary liaison between customers and technicians. They assess vehicle issues, provide cost estimates, and manage repair timelines.
- **Automotive Technician:** Performs inspections, maintenance, and repairs.
- **Tire Technician:** Specializes in tire repair, replacement, and road-safety maintenance.
- **Parts Specialist:** Manages inventory and supplies parts for the service department and customers.

3. Support & Operations

- **Car Detailer:** Cleans and prepares vehicles for sale or after service.

- **Cashier:** Processes payments for service and sales.
- **Vehicle Inspector:** Ensures vehicles meet safety and quality standards.

4. Management & Administration

- **General Manager / Dealer Principal:** Oversees total dealership operations, including staffing, marketing, and sales targets.
- **Service Manager:** Manages the workshop team and service quality.

Session II: Introduction to Sales Consultant Role & Responsibilities

Sales Consultant Role & Responsibilities

An Automobile Sales Consultant (or Salesperson) acts as a trusted advisor and bridge between a dealership and a customer, focusing on matching clients with vehicles that suit their specific needs, lifestyle, and budget. Beyond just selling, they manage the entire customer journey from the first greeting to post-delivery follow-ups.



Job Role and Core Duties

- **Customer Greeting and Needs Analysis:** Welcoming customers, identifying their requirements, and analyzing their budget/lifestyle to recommend the right vehicle.
- **Product Demonstration and Test Drives:** Offering detailed product knowledge (features, technology, specifications) and facilitating test drives to demonstrate vehicle benefits.
- **Negotiation and Closing:** Overcoming objections and negotiating final vehicle prices, trade-in values, and financing options in collaboration with sales management.
- **Relationship Management (CRM):** Utilizing Customer Relationship Management (CRM) tools to manage leads, follow up with potential prospects, and cultivate repeat/referral business.
- **Paperwork and Delivery:** Processing sales orders and necessary documentation, and preparing sold vehicles for delivery, ensuring the customer understands all features and warranties.
- **Vehicle Knowledge and Inventory Maintenance:** Keeping abreast of new vehicle models, technologies (especially EVs/hybrids), and competitor products, as well as keeping display vehicles clean and orderly.

Work Ethics and Professionalism

- **Integrity and Honesty:** Operating with transparency regarding vehicle history, pricing, and financing to build trust, rather than using high-pressure tactics.
- **Customer-Centric Focus:** Prioritizing helping the customer over making a quick sale, ensuring they leave satisfied.
- **Accountability and Ownership:** Taking initiative to meet or exceed monthly sales quotas while adhering to dealership policies and local regulations.
- **Resilience and Motivation:** Maintaining a positive attitude in a fast-paced, sometimes slow-moving, competitive environment.
- **Professional Appearance and Demeanor:** Presenting themselves and the dealership in a neat, professional manner.

Key Skills

- **Active Listening:** Understanding customer pain points rather than simply pushing a vehicle.
- **Negotiation and Persuasion:** Bridging the gap between the customer's budget and the dealership's goals.
- **Technological Proficiency:** Using CRM software, digital sales tools, and virtual showrooms.
- **Time Management:** Juggling multiple leads, follow-ups, and in-person customers simultaneously.

Session III: Importance of Sales in Business Growth

Importance of Sales in Business Growth

An organization works seamlessly when all the departments are in sync. If other departments are considered cost centers for business, then the sales department is the source of revenue generation.

Do you know organizations put a lot of effort into finding prospects, building long-term relationships with them, pitching the right products to them, and convincing them to choose products from you.?

All the activities lead businesses towards accomplishing a single business objective called profit. Earning profits is possible through increasing sales.

Hence, the sale is important for businesses without which the organization cannot survive. In this blog, we will delve deeper to make you understand what a sale is, the importance of sales, and a quick walkthrough of the sales process.



What is a Sale?



Sales primarily involve persuading the potential buyer to consider buying your product or service. As Henry Ford rightly said, “Nothing happens until and unless someone sells something.”

Therefore, Sales are regarded as the backbone of every industry, and salespeople are considered the lifeblood of organizations.

Organizations have dedicated sales departments who know what kind of products they are selling, who is the target customer for that product, etc.

Sales generally occur when an organization has sold its product to a customer who showed interest in the particular product or service.

Research says organizations spend around 1 trillion dollars on hiring salesforces”. Inbound report from HubSpot says salespeople get approximately 28% of leads from doing marketing”. Though terms like sales and marketing are used interchangeably, these are the 2 sides of the same coin.

Sales dominate every industry because it serves as an interface between customer needs and organizational products. Startups and big brands are searching for sales professionals who can find qualified leads who have the budget to buy company products or services.

Different types of sales happen in an organization. These include B2B sales, B2C sales, inside sales, outside sales, agency sales, consultative sales, etc.

What is The Importance of Sales



1. Sales Boost Conversions

Organizations have dedicated sales professionals who are responsible for selling products to the right set of audiences. The sales department deals with those customers who have some sort of awareness about the products.

As salespersons are in constant touch with customers, they help organizations generate a good amount of revenue.

2. Product/Market Fit

Businesses can experience increased sales when there is the right balance between product fit and market fit. A business cannot make sales when the wrong product is targeted to the customer or when businesses are using the wrong sales strategy to market their products. Therefore, sales happen when you find the best product/market fit.

3. Accelerates Business Growth

A business's growth depends on the sales department's success. Though a business has a large empire and great products; an enterprise becomes successful when most customers consider buying its products.

An increase in sales not only increases the size of the venture but also makes the business more profitable.

4. Build Good Relationships With Customers

The best salespeople in an organization are not only responsible for getting qualified leads, but they are the ones who add value to the life of employees and customers. Best salespeople know how to make their customer's life happy.

The targets of salespeople become accomplished when their customers are happy.

5. Builds Loyalty

Customers can recognize your brand and prefer to buy products from you if you have good sales. An efficient sales team uses various strategies to win the customer's trust, which in turn builds customer loyalty.

Session IV: Introduction to Role of Service Technician & Responsibilities

Role of Service Technician & Responsibilities

A **vehicle service technician** (also known as an automotive technician or service tech) is a skilled professional responsible for inspecting, maintaining, and repairing cars, light trucks, and other vehicles to ensure they run safely, efficiently, and reliably. Unlike traditional mechanics who may focus on simpler mechanical parts, service technicians frequently use advanced diagnostic computer systems to troubleshoot complex electrical, electronic, and mechanical issues.



Job Role & Responsibilities

- **Diagnose Vehicle Issues:** Use computerized diagnostic equipment, scan tools, and test drives to pinpoint malfunctions in engines, transmissions, electrical systems, and brake systems.
- **Routine Maintenance & Service:** Perform preventative maintenance, such as oil changes, fluid level checks, filter replacements, tire rotations, and tune-ups.
- **Repair and Replacement:** Disassemble, repair, or replace broken, worn, or defective components, including brake pads, sensors, and steering mechanisms.
- **Document Repairs:** Maintain detailed, legible records of services performed, parts used, and time spent, adhering to manufacturer warranty guidelines.
- **Customer Communication:** Advise service advisors or customers directly on required repairs, explain technical issues in understandable terms, and provide cost estimates.

Key Duties

- **Vehicle Inspection:** Conduct Multi-Point Inspections (MPI) to identify current and potential future faults.
- **Road Testing:** Test drive vehicles before and after repairs to verify issues and confirm proper functioning.

- **Electrical System Diagnosis:** Troubleshoot onboard computer systems, sensors, and high-voltage systems (in electric/hybrid vehicles).
- **Tool & Workstation Maintenance:** Keep tools, lifts, and work bays clean, organized, and safe.

Work Ethics

- **Honesty & Integrity:** Providing accurate diagnoses and recommending only necessary repairs to build customer trust.
- **Attention to Detail:** Meticulously observing small details to prevent misalignments or malfunctions, particularly when using diagnostic computers.
- **Commitment to Safety:** Strict adherence to safety protocols (OSHA) and environmental regulations regarding hazardous waste (e.g., oil, refrigerant disposal).
- **Continuous Learning:** Staying updated on new automotive technologies, including electric vehicles and advanced safety systems, by attending training classes.
- **Professionalism & Teamwork:** Collaborating with other technicians, mentoring apprentices, and maintaining a positive attitude.
- **Efficiency & Punctuality:** Completing repairs within established labor times and adhering to workshop deadlines.

Required Skills

- **Technical Knowledge:** Comprehensive understanding of mechanical, hydraulic, and electrical components.
- **Manual Dexterity:** Ability to work with small parts and in uncomfortable positions.
- **Physical Strength:** Ability to lift heavy objects, such as tires or body panels.

Session V: Importance of Service in Business Growth

Importance of Service in Business Growth

Excellent service acts as a primary catalyst for business growth by maximizing customer retention, driving revenue expansion, and creating a powerful competitive differentiator. Investing in service lowers acquisition costs—which are 5–7 times higher than retention—while increasing Customer Lifetime Value (CLV) through repeat business and referrals. Ultimately, high-quality service builds the trust necessary for long-term sustainability and brand loyalty.

Core Impacts on Business Growth

- **Cost Efficiency (Retention vs. Acquisition):** Retaining existing customers is significantly more cost-effective than acquiring new ones. Superior service reduces churn, ensuring a stable revenue base.
- **Differentiation in Competitive Markets:** When products or pricing are similar, the quality of service becomes the defining factor that separates a company from its competitors.
- **Increased Customer Lifetime Value (CLV):** Satisfied customers are more likely to make repeat purchases, upsell, or cross-sell, directly increasing the total revenue generated per account.
- **Brand Advocacy:** Exceptional service turns customers into brand advocates who refer new business through word-of-mouth, providing free, high-trust marketing.
- **Data-Driven Improvement:** Service interactions provide critical, real-time feedback loops that allow businesses to refine their products, services, and operational processes.

Strategic Implementation

To leverage service for growth, businesses often focus on:

- **Empowering Employees:** Well-trained staff who are empowered to solve issues feel more pride in their work, which increases both morale and service quality.
- **Utilizing Technology:** Implementing service software or AI can help manage high volumes of inquiries, ensuring consistent, responsive support as the company scales.
- **Personalization:** Delivering a service experience tailored to individual client needs fosters deeper loyalty.

Unit III

Health and Safety at Workplace

Session I: Workplace Safety Rules

Introduction

Safe working in a vehicle service workshop involves using proper personal protective equipment (PPE), maintaining a clean and organized workspace, using and inspecting equipment correctly, and following safe work practices like proper lifting and chemical handling.

Hazards in Vehicle Service Workshop



Mechanical hazards

- **Moving machinery:** Risks from unguarded moving parts of tools and equipment.
- **Falling objects:** Injuries from parts or tools falling, or from a vehicle falling from a lift or jack.
- **Heavy lifting:** Injuries from handling heavy parts like wheels and tires, and ergonomic injuries from awkward postures or repetitive motions.
- **Punctures:** Injuries from burst tires or sharp objects.

Chemical hazards

- **Fumes and vapors:** Inhalation of exhaust fumes, solvents, and other chemicals that can cause respiratory or systemic damage.
- **Skin and eye contact:** Burns, irritation, and inflammation from contact with solvents, degreasers, and other corrosive or irritating substances.

Fire and explosion risks

- **Flammable materials:** The presence of gasoline, oils, and other flammable liquids can lead to fires.
- **Tire explosions:** Risks associated with compressed air and tires.

Slips, trips, and falls

- **Slick surfaces:** Grease, oil, and brake fluid on floors are a major hazard, and cords or hoses left on the floor can cause people to trip.

Electrical hazards

- **Electrical systems:** Risks from shocks or short circuits when working on vehicle electrical systems.
- **Equipment:** Injuries from faulty or improperly maintained electrical tools.

Auto Shop Safety

Safety at automobile workshop

- Personal Safety: Observe the following general safety precautions while working in automotive workshop
- Don't indulge in horseplay
- Don't scatter the tools etc. on the operating machinery
- Don't keep sharp objects or tools in your pocket
- See that your dress is suited to the job. It should not be loose which may get caught in the moving machinery
- Never use compressed air for blowing out dirt from your clothes
- While chipping, grinding or using air hose or doing any other job where there is danger of flying particles, goggles must be worn
- When car is jacked up, make sure the jack is properly centered and will not slip.

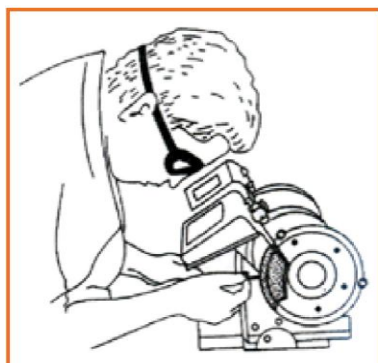

Safety with hand tools

- Use the correct tool for the job in hand
- Use the tool correctly
- Keep the tools clean and in good working condition
- Grease or oil on tools should be wiped off as it is difficult to hold and use such tools

- Store the tools in their proper places

Safety with power tools

There are three main dangers with the use of power tools:

- Electric shock: The safety precautions are —
 - Don't use damaged chords
 - Don't stand in water or even wear wet shoes when working with electrical equipment
 - Make sure the electrical equipment is properly earthed
- Flying metal chips the safety precautions is — ALWAYS WEAR GOGGLES
- Injuries due to unsafe use of tools: The safety precautions are:
 - Carefully study the instructions before using any equipment
 - Keep hands and clothes away from moving parts
 - Make sure the electrical equipment is properly earthed
 - When working on devices like clutches, valves etc. which have springs, make sure the springs will not slip or jump off
 - Don't adjust or oil moving part of a machine

Personal Protective Equipment (PPE)

While working on shop floor every worker has to take care of several things about personal safety and also safety of its co-workers. To avoid certain accidents and hazards, person has to take different precautions for different situations.

Firstly, on shop floor every person has to wear person protective equipment (PPE) for its personal safety.

What is Personal Protective Equipment?

PPE is defined as “All equipment which protects the worker from risks and hazards while working at workplace”. PPE safeguard us from work place hazards

Types of PPE

1. **Eye Protection:** Eye Protection is a must when working on cars. Eyes are so fragile. Safety glasses and goggles will help prevent foreign materials from entering your eyes. These are especially important when inspecting the underbody of a vehicle and working around chemicals. Goggles can be used over prescription glasses.
2. **Gloves:** Use work gloves when you are performing work on tyres or exhaust. Extremely worn tyres can have sharp steel belts poking from the tread. Exhaust systems can be hot and have rusty holes that can cut your hands. Use disposable latex gloves when you are working with chemicals, oils, and grease.



3. **Head Protection:** Hard hats guards from collision and penetration hazards also from burns and electrical shock hazards. Make sure that head protection is available where following risks can happen:

- Falling objects
- Contact of head with electricity sources accidentally



4. **Foot Protection:** Safety boots guard the feet from puncture wounds, injuries and slipping. Make sure that foot protection is available where following risks can happen:

- When heavy objects roll on or fall on the feet;
- Working with pointed items like nails or wires
- Risk if falling of molten metal on feet or legs;
- Working on warm, damp and greasy surfaces.



5. **Ear Protection:** Use earplugs or earmuffs when the work area is excessively loud. Noise with high decibel levels can damage your hearing. Earplugs are made of waxed cotton, foam, silicone rubber or fiberglass wool. They are self-forming and, when properly inserted, they work as well as most molded earplugs. Earplugs save the ears from loud noise at the workshop.



6. **Body Protection:** There are many varieties of protective clothing available for specific hazards. Protective clothing comes in a variety of materials, each effective against particular hazards, such as:

- Paper-like fiber used for disposable suits provide protection against dust and splashes.
- Treated wool and cotton adapts well to changing temperatures, is comfortable and fire-resistant and protects against dust, abrasions and rough and irritating surfaces.
- Leather is often used to protect against dry heat and flames.
- Rubber, rubberized fabrics, neoprene and plastics protect against certain chemicals and physical hazards.





Safe Working Practices in Workshop



- **Proper Storage:** Store tools and equipment in their designated places. Do not leave parts or tools on the floor where they can cause trips.
- **Clear Walkways:** Keep walkways and exits clear of obstructions.
- **Fire Safety:** Place oily rags in a designated metal container, as they can spontaneously combust. Ensure fire extinguishers are accessible and appropriate for the area.
- **Inspect Equipment:** Check all machinery and equipment for proper working order before use. A malfunctioning machine can cause serious injury.
- **Use Correctly:** Only operate equipment you are trained to use.
- **Guards and Shields:** Keep all guards and shields in place on machines.
- **Disconnect Power:** Always disconnect power before servicing any equipment.
- **Disconnect Battery:** Always disconnect the battery before working on electrical systems.
- **Proper Lifting:** Use proper lifting techniques and equipment like trolleys when handling heavy parts to prevent injury.
- **Vehicle Support:** Never work under a vehicle that is not properly supported with jack stands.
- **Do Not Work Alone:** It's safer to have someone else in the workshop with you, especially for high-risk tasks.

Session II: Personal Hygiene and Cleanliness

Workplace Hygiene

All workplace environments need to be hygienic and safe for both employees and visitors. This applies to all, not just workplaces involved in handling food and personal products.

A solid workplace hygiene policy is the best way to ensure employees maintain a clean workplace.

Each workplace will require different hygiene requirements. Certain tasks, or industries may also create risks which require additional protection than those discussed below. However, below are some key areas all workplaces should consider for their workplace hygiene policy.

Why Is Hygiene Important in the Workplace?

Hygiene is important in the workplace because it contributes to a healthy workforce. A healthy workforce is happier and more productive. A healthy workplace also means workers take less sick leave. Which will reduce the huge cost that sick leave places on small business.

How Do You Maintain Hygiene in the Workplace?

Implement a hygiene policy

Provide staff with a written hygiene policy. Inform them of your intentions and expectations of a clean workplace. This helps communicate to staff that you also take workplace hygiene seriously.

Provide a clean bathroom

It is pivotal for a hygienic workplace to have a clean bathroom. Also ensure that the bathroom is well stocked with soap, toilet paper and hand towels.

Provide clean wipes, sanitiser and tissues

Provide items such as these to help your staff maintain a clean and hygienic workspace. Employees are more likely to use such items if they are readily available.

Regular cleaning

Make sure your workplace is regularly cleaned. This helps prevent the spread of infection, and a cleaned workplace also maintains morale and a sense of professionalism.

What Is the Basic Hygiene in a Workplace?

Basic hygiene in the workplace can be put down to four different things: personal hygiene; work area cleanliness; clean restroom facilities; and a clean kitchen.

Why Is Personal Hygiene Important in the Workplace?

Personal hygiene refers to the cleanliness, appearance and habits of employees. Personal hygiene of employees, for obvious reasons, can be a sensitive issue for business owners.

A well-groomed personality projects a good image and speaks well of hygiene and efficiency. As far as possible, personnel should —



- be fresh, well-groomed and clean, not half asleep or unkempt in appearance while reporting on duty
- have their hair neatly cut and tied properly
- have nails neatly trimmed
- dress in simple, clean and well ironed clothes
- avoid rings or other jewellery
- use light makeup, in case of women
- use footwear that is light, without heels and noiseless
- be healthy and not suffer from any skin disease, colds, etc.
- avoid bad habits such as nail biting, nose picking, leg shaking, sitting on work table, spitting, chewing pan, smoking, etc.
- bathe daily.

Workplace Sanitization

Cleaning and disinfecting are part of a broad approach to preventing infectious diseases in the workplace. To help slow the spread, cover coughs and sneezes with your elbow or tissue; wash your hands, and keep sick people away from others. It is important to make employees aware that if they feel ill, stay home from work. Below are tips on how to slow the spread of germs specifically through cleaning and disinfecting.

1. Know the difference between cleaning, disinfecting, and sanitizing

Cleaning removes germs, dirt, and impurities from surfaces or objects. Cleaning works by using soap (or detergent) and water to physically remove germs from surfaces. This process does not necessarily kill germs, but by removing them, it lowers their numbers and the risk of spreading infection.

Disinfecting kills germs on surfaces or objects. Disinfecting works by using chemicals to kill germs on surfaces or objects. This process does not necessarily clean dirty surfaces or remove germs, but by killing germs on a surface after cleaning, it can further lower the risk of spreading infection.

Sanitizing lowers the number of germs on surfaces or objects to a safe level, as judged by public health standards or requirements. This process works by either cleaning or disinfecting surfaces or objects to lower the risk of spreading infection.



2. Clean and disinfect surfaces and objects that are touched often

Follow organization's standard procedures for routine cleaning and disinfecting. Typically, this means daily sanitizing surfaces and objects that are touched often, such as desks, countertops, doorknobs, computer keyboards, faucet handles, and phones. Standard procedures often call for disinfecting specific areas, like bathrooms.

Immediately clean surfaces and objects that are visibly soiled. If surfaces or objects are soiled with body fluids or blood, use gloves and other standard precautions to avoid coming into contact with the fluid. Remove the spill, and then clean and disinfect the surface.

3. Simply do routine cleaning and disinfecting

It's important to match your cleaning and disinfecting activities to the types of germs you want to remove or kill. Most studies have shown that some viruses can live and potentially infect a person for only 2 to 8 hours after being deposited on a surface. Therefore, it is not necessary to close organizations to clean or disinfect every surface in the building to slow the spread of germs. Also, if employees are dismissed because the organization cannot function normally (e.g., high absenteeism during a flu outbreak), it is not necessary to do extra cleaning and disinfecting.

Some viruses are relatively fragile, so standard cleaning and disinfecting practices are sufficient to remove or kill them. Special cleaning and disinfecting processes, including wiping down walls and ceilings, frequently using room air deodorizers, and fumigating, are not necessary or recommended. These processes can irritate eyes, noses, throats, and skin; aggravate asthma; and cause other serious side effects.

4. Clean and disinfect correctly

Always follow label directions on cleaning products and disinfectants. Wash surfaces with a general household cleaner to remove germs. Rinse with water, and follow with an EPA-registered disinfectant to kill germs. Read the label to make sure it states that EPA has approved the product for effectiveness against specific viruses.

If a surface is not visibly dirty, you can clean it with an EPA-registered product that both cleans (removes germs) and disinfects (kills germs) instead. Be sure to read the label directions carefully, as there may be a separate procedure for using the product as a cleaner or as a disinfectant. Disinfection usually requires the product to remain on the surface for a certain period of time.

Routinely wash eating utensils in a dishwasher or by hand with soap and water. Wash and dry bed sheets, towels, and other linens as you normally do with household laundry soap, according to the fabric labels. Eating utensils, dishes, and linens used by sick persons do not need to be cleaned separately, but they should not be shared unless they've been washed thoroughly. Wash your hands with soap and water after handling soiled dishes and laundry items.

5. Handle waste properly

Follow standard procedures for handling waste, which may include wearing gloves. Place no-touch waste baskets where they are easy to use. Throw disposable items used to clean surfaces and items in the trash immediately after use. Avoid touching used tissues and other waste when emptying waste baskets. Wash hands with soap and water after emptying waste baskets and touching used tissues and similar waste.

Ways to maintain personal sanitization

Maintain social distancing, staying six feet away from others. Reduce sharing of common spaces and frequently touched objects.

- Wear disposable gloves to clean and disinfect and discard after use or use reusable gloves that are dedicated only for cleaning and disinfecting. Always wash hands after removing gloves.
- Clean any dirty surfaces using soap and water first, then use disinfectant.
- Cleaning with soap and water reduces the number of germs, dirt, and impurities on the surface. Disinfecting kills any remaining germs on surfaces, which further reduces any risk of spreading infection.
 - Practice routine cleaning and disinfection of frequently touched surfaces. More frequent cleaning and disinfection may be required based on level of use.
 - Surfaces and objects in public places, such as shopping carts, point of sale keypads, pens, counters, vending machines, and ATMs should be cleaned and disinfected before each use or as much as possible.
 - Other high touch surfaces include: Tables, doorknobs, light switches, countertops, handles, desks, phones, keyboards, toilets, faucets, sinks.

When cleaning

- Wear disposable gloves and gowns for all tasks in the cleaning process, including handling trash.
 - Additional personal protective equipment (PPE) might be required based on the cleaning/disinfectant products being used and whether there is a risk of splash.

- Gloves and gowns should be removed carefully to avoid contamination of the wearer and the surrounding area.
- Wash your hands often with soap and water for 20 seconds.
 - Wash your hands immediately after removing gloves and after contact with a person who is sick.
- Follow normal preventive actions while at work and home, including washing hands often for at least 20 seconds and avoiding touching eyes, nose, or mouth with unwashed hands. It is especially important to wash hands:
 - After blowing one's nose, coughing, or sneezing.
 - Before touching one's face.
 - After using the restroom.
 - After leaving a public place.
 - After handling one's mask.
 - After changing a diaper.
 - Before eating or preparing food.
 - After touching animals or pets.
 - After caring for an ill person.

Hand sanitizer: If soap and water are not available and hands are not visibly dirty, an alcohol-based hand sanitizer that contains at least 60% alcohol may be used. However, if hands are visibly dirty, always wash hands with soap and water for at least 20 seconds.

Session III: Fire Safety and Emergency Procedures

Fire Hazards

Fire is one of the most common causes of the accidents in establishments. Fire is defined as a self-sustaining combustion process in which a substance (fuel) combines with oxygen in air to produce immense heat and light.

Fire hazards pose threats to life and property. It is, therefore, the prime object of safety systems to detect, remove or reduce the risk of fire threatened by those potential hazards.

The following fire hazards are common at home, in public places, transports and work places:

- All types of flames used for any work
- Electric wires, higher loads, loose connections and old electrical equipment
- All cooking and heat generating appliances
- All works and situations where fire is essential such as welding, cutting, metal casting etc.
- Improper stowage of tools, equipment and items during and at the end of the day's work
- Smoking and personal lighters and matches
- Fireworks, pyro techniques, ammunitions and explosives
- Improper and unauthorized stowage of flammable and hazardous materials and chemicals especially the flammable ones
- Insufficient capacity and numbers of emergency exits and stairs
- Hindrance to sight or reach fire-fighting equipment, markings and alarm systems
- Insufficient numbers and types of fire extinguishers
- Absence of fire detection and alarm system
- Violation of building and fire codes

Fire Preparedness Procedures

Follow these emergency instructions in case of fire:

- Activate the ALARM.
- Evacuate the area.
- Call the fire department.
- Fight the fire only if:
 - You know how.
 - The fire is small.
 - You are confined to the area where it started.
 - You have a way out.
 - You can work with your back to the exit.
 - You have the right type of extinguisher.
 - You feel confident that you can operate it effectively.
- DO NOT fight the fire if:



- You have any doubts about fighting it.
- It is spreading beyond the area where it started.
- It could block your escape route.

Evacuate the building immediately

Confine a fire to the zone of origin, for a specified time, thereby preventing fire spread and leaving more time for safe evacuation of the building occupants.

If a fire breaks out, smoke containment systems prevent the movement of smoke and heat from one area to another.

Fire Prevention

Follow these steps for fire prevention:

- Don't allow trash and litter to accumulate unnecessarily
- Keep the workplace areas neat and clean
- Know where fire alarm boxes and extinguishers are located
- Ensure you know the different types of fire extinguishers and how to use them
- Store hazardous materials in designated areas
- Keep exits free of obstructions
- Know location of emergency exits and procedures
- Handle flammable liquids with caution

Fire Extinguishers

Types of fire

Class of Fire	Description	Mode of Extinguishing	Medium of Extinguishing	Type of Extinguisher
A 	Fire involving solid material (fuel) for combustion like wood, paper, plastics that melt.	Cooling	Water	<ul style="list-style-type: none"> • Water • Soda-Acid Type • CO₂ Gas Type
B 	Fire involving flammable liquids like petrol, diesel, thinners, cooking oils, paints, wax and plastics that	Blanketing	Foam CO ₂ , Halon, DCP	<ul style="list-style-type: none"> • Foam • CO₂ • DCP • Halon Type
C 	Fire caused by electricity equipment	Cutting off electricity supply	Vaporising liquids, dry powder and CO ₂	<ul style="list-style-type: none"> • CO₂ • DCP • Halon • Dry Sand
D 	Fire involving flammable metals like magnesium, titanium	Smothering	Suitable dry powder	<ul style="list-style-type: none"> • Special DCP extenguisher • Dry Sand • Powered Grephte • Talc and Absestos • Limestone

Specific types of fire-extinguishers and their uses:

Fire Extinguishers	Uses
Water	<ul style="list-style-type: none"> • Pressurized, pump type • Cools fire • Use on Class A fires • Do not use on B or C fires
Multi Purpose Dry Chemical	<ul style="list-style-type: none"> • Stored pressure type • Smothers fire with layer of powder • Use on Class A, B and C fires
Chemical Foam	<ul style="list-style-type: none"> • Aqueous film forming foam (AFFF) type • Smothers fire with foam • Use on Class A and B fires
Compressed Gas	<ul style="list-style-type: none"> • Halon, CO₂ types • Smothers fire with gas • Use on Class B and C fires

Colour Codification of Fire Extinguishers

Type	Old Code	BS EN 3 Colour Code	Fire Class
Water	Signal Red	Signal Red	A
Water Mist	White and Red	White and Red	A (B, C, electrical if dielectrically tested)
Foam	Cream	Red with a cream panel above the operating instructions	A B
Dry Powder	French Blue	Red with a blue panel above the operating instructions	A, B, C
Carbon Dioxide		Red with a black panel above the operating instructions	
Halon		No longer produced – illegal in the UK	A
Wet Chemical	Not in use	Red with a yellow panel above the operating instructions	A

Using a Fire Extinguisher



P.A.S.S. is an acronym that can help you remember how to use the extinguisher. Follow the P.A.S.S. Method:

- Pull the extinguisher's pin
- Aim the nozzle at the base of the fire
- Squeeze the handle to discharge the agent
- Sweep the nozzle back and forth

Emergency Procedures

Every workplace should have a plan for dealing with emergencies. You should be instructed in that plan within your first few days on the job and have refresher training from time to time.

Once you have been trained, you should be able to answer these questions during an emergency:

- Where the emergency phone numbers are posted?
- Where are the fire extinguishers and how and when should they be used?
- What other specialized equipment may be needed in an emergency, and how it is used?
- Where are the fire alarms and fire exits?
- What is the evacuation plan for the building?
- What should you do during an earthquake?

- In case of evacuation, where outside the building is the assembly point and who should you report to?

Emergency Service Number

Dial the service number of these departments in case of emergency:

- Fire Brigade Department
- Police Department
- Ambulance Department
- Women Safety Department
- Security Department
- Pest Control Department



Medical Emergency Procedures

Follow these steps for medical emergency procedures:

- An emergency medical service should be available near to your dealership
- At least one person should be trained enough to handle any medical emergency
- First-aid supplies should be available at the dealership
- Check – Call – Care route should be followed



Evacuation Procedures for Workers & Visitors

Let's now learn about the for evacuation procedures for workers & visitors in case of emergency.

As the first step a layout must be made of the building, including:

- Evacuation Routes

- Fire Extinguisher (locations)
- Fire Alarm Stations (locations)
- First Aid Kit (locations)

The second step for evacuation procedures for workers & visitors in case of emergency includes a map of the building, parking area and other buildings surroundings.

This must show the Rally Point. Rally Point must be a safe distance from the building. It must be easily accessible, out of the way of emergency services, and should not be beside the fire hydrant. Both the layout and the Rally Point must be posted noticeably throughout the facility and made accessible to all employees upon request.

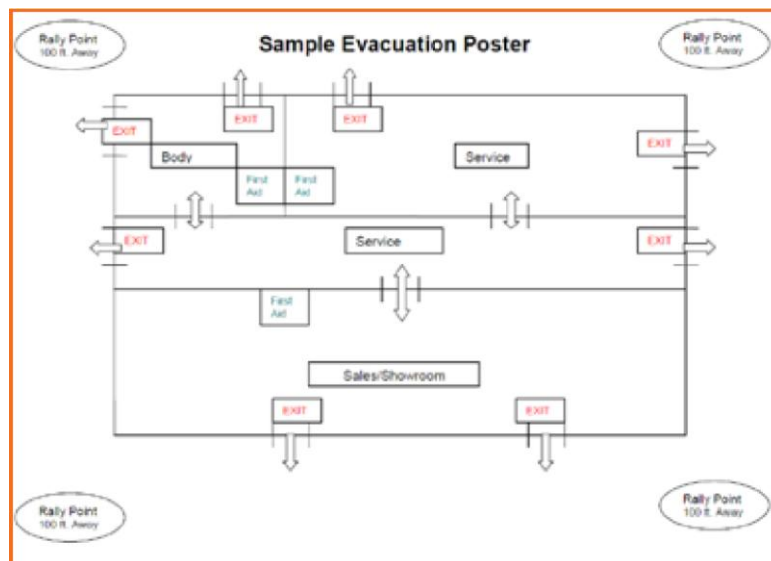

Session IV: Safe Handling of Equipment

Safe Handling of Equipment

Safe handling of machines and tools in a service workshop requires a combination of proper training, consistent use of Personal Protective Equipment (PPE), and adherence to safety protocols like lockout/tagout. The primary goal is to prevent injuries from moving parts, sharp edges, flying chips, and electrical hazards.

General Workshop Safety Rules

- **Training & Authorization:** Only operate machinery after receiving proper instruction.
- **PPE:** Safety glasses with side shields are mandatory. Use ear protection for high noise levels and safety shoes for foot protection.
- **Dress Code:** Avoid loose clothing, dangling jewelry, and tie back long hair to prevent entanglement.
- **Housekeeping:** Keep work areas clean and free of obstacles to prevent slips and trips.
- **No Horseplay:** Focus on tasks; do not distract others.
- **No Alcohol/Drugs:** Never work under the influence of alcohol or medication.

Safe Tool Handling

- **Right Tool for the Job:** Do not use tools for improper purposes (e.g., using a screwdriver as a pry bar or a wrench as a hammer).
- **Condition:** Ensure hand tools are clean and in good working condition. Replace splintered handles or tools with "mushroomed" heads.
- **Sharpness:** Keep blades sharp to prevent them from binding or slipping.
- **Carrying:** Do not carry sharp tools in pockets; use toolboxes or pouches.
- **Storage:** Return tools to their designated storage areas after use.

Maintenance & Electrical Safety

- **Lockout/Tagout (LOTO):** Always isolate machines from energy sources (electrical, hydraulic, pneumatic) before maintenance.
- **Defective Equipment:** Immediately report and tag out of service any malfunctioning equipment.
- **Electrical Hazards:** Inspect cables for damage and ensure tools are properly grounded.



Common Risks and Prevention

- **Entanglement:** Caused by loose clothing, long hair, or gloves near rotating parts.
- **Flying Particles:** Eye injuries from metal chips or wood shavings.
- **Slips/Falls:** Caused by oil, grease, or debris on the floor.

Session V: First Aid Basics

Basic First-aid Techniques

Free a person from electrocution

If find someone is suffering from electric shock, approach with extreme caution and following first aid steps.

Steps

1. **Firstly take** the suffered person away from the electricity source as fast as possible. Turning off the electric supply of machine is the best method for doing this.
2. If this seems impossible, remove the person from electricity source by using a piece of wood or insulating material.
3. **Don't touch the victim getting the electric shock** because you could also get shock too.
4. **After successful executing the victim from the electricity source**, call the ambulance, if victim is unconscious. Give first-aid to victim till the time ambulance is coming.
5. **If victim is conscious** and looking well, monitor its condition, as the results of shock must not be clear immediately.



First-aid in case of bleeding, burns, choking, electric shock, poisoning etc

For treating shock, burns, bleeding and wounds, electric shock, choking, eye injury, heat stroke, hypothermia, fainting and unconsciousness, use following first-aid techniques:

Shock

Cold, weakness, unbalanced breathing, rapid weak pulse, pale or bluish lips and fingernails and nausea are the symptoms of shock.

Steps

1. Don't give anything for eating and drinking to victim.
2. Put down the victim on his/her back. Don't move the victim if there's any neck or back injury. If find victim is unconscious or vomiting, put down on his/her side and ensure that sufficient air is available in the room.
3. Use blankets or clothes to keep the victim warm.
4. Place the victim's legs on a pillow.

Bleeding and Wounds

Steps

1. Cover the wound by a clean cloth and gloved hand; then apply firm and steady pressure on wound for 5 mins at least.
2. Lift up the injured leg or arm above the victim's heart level.
3. Secure the wound by a bandage when bleeding stops. Ensure that bandage is not fixed too tightly—it may stop blood circulation.
4. Check the victim for shock.

Burns**Steps****Chemical or Compressed Gas Burns**

1. Use a drench hose and emergency shower for at least 15 mins to rinse away all residues of chemicals.
2. Cover the burn by a clean and dry cloth or special dressing for burns.
3. Check the victim for shock.

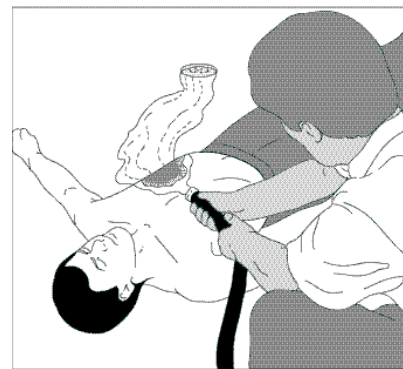
**Heat or Electrical Burns**

1. Cool burning of skin by water.
2. Place the burned area under cold running water if the skin is not broken and gently compress the wound by hand. Bandage the wound by a dry and clean cloth.
3. If blister appear, don't try to break it.
4. Do not apply ointments or creams.
5. If skin is cracked, or if injuries are severe:
 - Do not clean the wound or remove embedded clothing.
 - Cover the injury insecurely with a clean, dry cloth.
 - Expect shock and treat accordingly.

Choking

The patient is talking and getting sufficient air; don't restrict it if he/she tries to cough the obstruction in the throat. If the patient can't talk or not getting enough air, make call on emergency number.

Steps

1. Wrap your arms around the stomach and stand directly behind the victim.



Just above the navel and well below the ribs, make a fist by a hand. Place that fist with the thumb and forefinger side toward you.

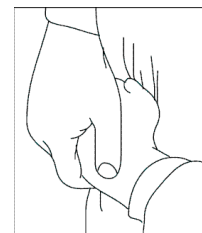

2. Hold the fist by other hand and pull it rapidly towards you by a slightly upward and inward thrust. If required, repeat it.



If the patient becomes insentient:

1. Put down the patient on their back.
2. If the object that is obstruct the airway is noticeable, reach a finger into the patient's mouth and try to bend the obstruction out of the patient's throat, being careful not to push the object deeper into the patient airway.
3. Even if this is not successful, attempt rescue breathing.
4. A chest compression (CPR) is more helpful if the victim is still not breathing or moving.

Basic Techniques of Bandaging

The key points when applying a bandage are:

Steps

1. Make sure the person is comfortable.
2. Never lean across their body and ensure that you are working from the side of the injury.
3. First clean the wound and apply the antibacterial cream over it.
4. When the bandage is on always remember keep the injured part of the body supported in the position it will be in.
5. Always use right size of bandage.
6. To check the passage easily, don't cover fingers or toes when bandaging a limb.
7. Never wrap the bandage tight, and secure the end by folding it over and binding a knot in the end. Safety pin, adhesive tape, or a bandage clip can be used.



Artificial respiration and CPR Process

CPR instructions

- Check the Passage - make sure it is harmless for you to help.

- Don't become another patient.

CPR Steps

1. Check the Victim - tap and shout to get response.
2. Circulation - pump the chest 30 times.
3. At the center of the chest put the heel of one hand and your other hand on top of it. At a rate of 100 per minute (16 compressions in 10 seconds) press chest down 2 inches.
4. Tilt head back, lift chin up to open airway - Airway.
5. Breathing - Tweak nose closed, take a normal breath, cover patient mouth with yours and blow out your breath until you see the chest rise. One breath per 1 second. Again open airway again if chest doesn't rise.
6. Repeat procedure until help arrives or the victim begins breathing.

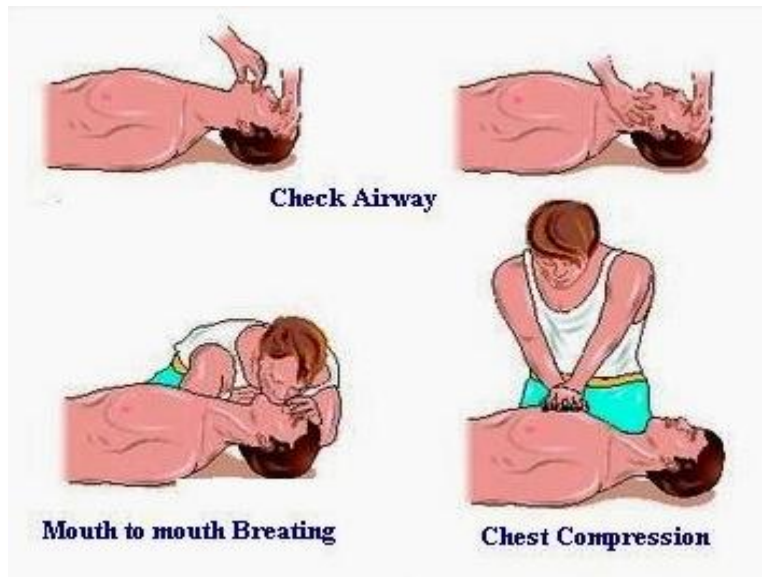

Correct method to move injured people and others during an emergency

To carry injured people to medical help or rescue from further harm. In these cases, you must consider the number of rescuers you have, the capabilities of these rescuers and the condition of the patient that must be stimulated. Below discussion on several ways to carry an injured person:

Steps

1. Stand on either side of the conscious victim. Grab the victim's wrist with the hand closest to the victim's feet on your side.
2. Use your other hand to grasp the clothing on the shoulder nearest to you and pull the victim's arms to help them to a sitting position.
3. Assist the victim to his or her feet and place the arms around your shoulders, if possible.



4. Place your free hand around the person's waist and let him or her set the pace on hobbling out.
5. Help the victim for moving slowly.

Unit IV

Basic Product Knowledge (Automobile)

Session I: Importance of Product Knowledge in Sales & Service

Introduction

Product knowledge is the foundation of sales and service because it builds immediate credibility and trust. It allows you to move beyond basic specs to provide tailored solutions that solve specific customer problems. Without it, you risk losing sales, appearing incompetent, and damaging your brand's reputation.

Why It Matters

- **Trust & Credibility:** Buyers can instantly sense uncertainty. Deep knowledge makes you sound confident and reliable, which is essential for closing deals.
- **Effective Problem Solving:** Instead of guessing, you can accurately match products to customer needs, ensuring higher satisfaction.
- **Handling Objections:** Competent knowledge helps you address concerns confidently before they become barriers.
- **Clear Communication:** You can explain complex features and benefits in simple, persuasive terms, reducing customer confusion.
- **Personalization:** Understanding the product inside and out allows you to tailor your pitch to specific preferences, making customers feel valued.

Impact on the Business

- **Higher Conversion Rates:** Customers are more likely to buy when they feel informed and supported.
- **Improved Loyalty:** Providing accurate, helpful guidance leads to repeat business and long-term relationships.
- **Professional Image:** Employees who know their products appear competent, whereas a lack of knowledge can make the entire company look untrained.

Knowing Your Product and Services

To defeat the competitors, it's important to gain in-depth knowledge about the product offerings and their place in the market. Successful salespersons are qualified learners who have gained knowledge of even the, most minor offering details. That's because knowledge is one of the most significant assets at their disposal.

One of the keys to being a great salesperson is identifying what the customers want and meeting their expectations. This requires asking right questions and listening twice.

As mentioned earlier, most customers spend a decent amount of time researching online, so it's safe to assume that most of them already have a specific vehicle in mind by the time they meet a salesperson.

However, asking them the right questions like, “What sort of features or feelings do they want from their automobile?” make it easier to pitch them similar options and open up a window of options to choose from that they probably haven't even thought of.

A good salesperson may show the customer their preferred vehicle and other similar options before they even visit the dealership outlet by sending them walk-around videos. The idea is to get them into the dealership with an open mind and drive off with a new vehicle.

When one hears the term “Product Knowledge” the first thing that usually comes to mind is knowing insignificant details about the product offered for sale. However, the topic of product knowledge is very subjective, and every good salesperson must have a good understanding of these four critical areas of knowledge

1. Customer Needs
2. Products
3. Marketplace
4. Competition.

Knowing your products and services means that the people selling the products or services have a great understanding and knowledge of what it is that they're offering, and the benefits customers can derive from it. Some of the other advantages of knowing your product are as follows:

Helps to respond to any objections appropriately
Enhances Confidence
Increases confidence
Increases customer retention
Boosts sales

Automotive sales executives must be aware of the new product launches and schemes to ensure smooth sales. It is important to inform the customers of any recent product launches or sales schemes.

While engaging customers, automotive sales executive should use their knowledge to lead customers through the product features and benefits and make their experience an enjoyable one that they'll want to revisit.

Successful salespeople utilize their products' features and skillfully turn leads into customers. To practice this skill, an automotive sales executive should list down the product's features, potential benefits, and all information upfront for your customers.

The table below highlights the possible benefits customers could obtain from the product features.

Purpose	{	Meets customer's needs and saves time and money
How it works	{	Easy to use
How it is developed or manufactured	{	Supports local industry and helps the environment
How it is delivered	{	Don't worry about delivery, will be arranged
How it is maintained and serviced	{	If required, will be taken care of
How long it is likely to last (including any warranties)	{	Will fix or replace it while under warranty
Its price	{	Affordable
How it compares to competitors' products	{	Base customer's decision on the good reputation the business has earned for selling other well-regarded products
How it compares to similar products the business offers	{	Quality and value for money
Its strengths and limitations	{	A product that is well-matched to your particular needs

Session II: Anatomy of all Type of Vehicles

Anatomy of Vehicles

The anatomy of a vehicle is a complex assembly of thousands of parts working together, generally organized into six main systems: the Chassis/Frame, Power Unit (Engine), Transmission, Suspension, Steering and Braking systems. While layouts vary between passenger cars, commercial trucks, two-wheelers, and electric vehicles (EVs), the foundational structural and functional principles remain similar—to convert energy into mobility.

1. Structural Anatomy (The Skeleton)

- **Chassis:** This is the foundational undercarriage, comprising the frame, suspension, axles, and wheels. It provides the structural backbone.
- **Frame/Body:**
 - **Body-on-Frame (Conventional):** A separate steel frame supports all mechanical parts, with the body bolted on top. Common in trucks and SUVs.
 - **Unibody (Frameless):** The body and frame are integrated into a single structure. Common in passenger cars for lighter weight.
- **Engine Cradle:** A sub-frame within the chassis designed to hold the engine securely.

2. Functional Anatomy (The Systems)

- **Power Unit (Engine/Motor):** Converts fuel (gasoline/diesel) or electricity into torque.
 - **IC Engine Components:** Pistons (move up/down), Crankshaft (converts motion to rotation), Valves (intake/exhaust), Camshaft (controls valves), Timing Belt/Chain.
 - **EV Motor:** Uses a battery pack, inverter, and electric motors to propel the vehicle.
- **Drivetrain & Transmission:** Transfers power from the engine to the wheels.
 - **Transmission:** Gearbox that changes output speed/torque (Automatic or Manual).
 - **Driveshaft/Propeller Shaft:** Transfers rotation from transmission to the differential.
 - **Differential:** Allows wheels to rotate at different speeds (crucial for turning).
 - **Axles:** Shafts connecting the differential to the wheels.
- **Suspension System:** Connects the chassis to the wheels, absorbing road shocks using springs, dampers, and linkages for comfort and stability.
- **Steering System:** Links the driver's steering wheel to the wheels, allowing directional control (rack-and-pinion is common).

- **Braking System:** Uses hydraulic pressure (brake fluid) to force pads against discs (disc brakes) or shoes against drums (drum brakes) to stop the vehicle.
- **Electrical System:** A "nervous system" that includes the battery (power storage), alternator (recharges battery), and ECU (Engine Control Unit).

Vehicle Anatomy by Type

Vehicle Type	Key Structural Features	Typical Functional Focus
Passenger Car	Unibody, lightweight materials.	Comfort, efficiency, handling.
Commercial Truck	Body-on-frame, heavy-duty suspension.	Torque, towing capacity, durability.
Two-Wheeler	Cradle frame, minimal bodywork.	Balance, agility, power-to-weight.
Electric (EV)	Battery pack integrated into floor ("skateboard").	Immediate torque, regenerative braking.
Off-Road/SUV	Ladder chassis, 4WD/AWD, high clearance.	Traction, suspension articulation.

Two Wheeler

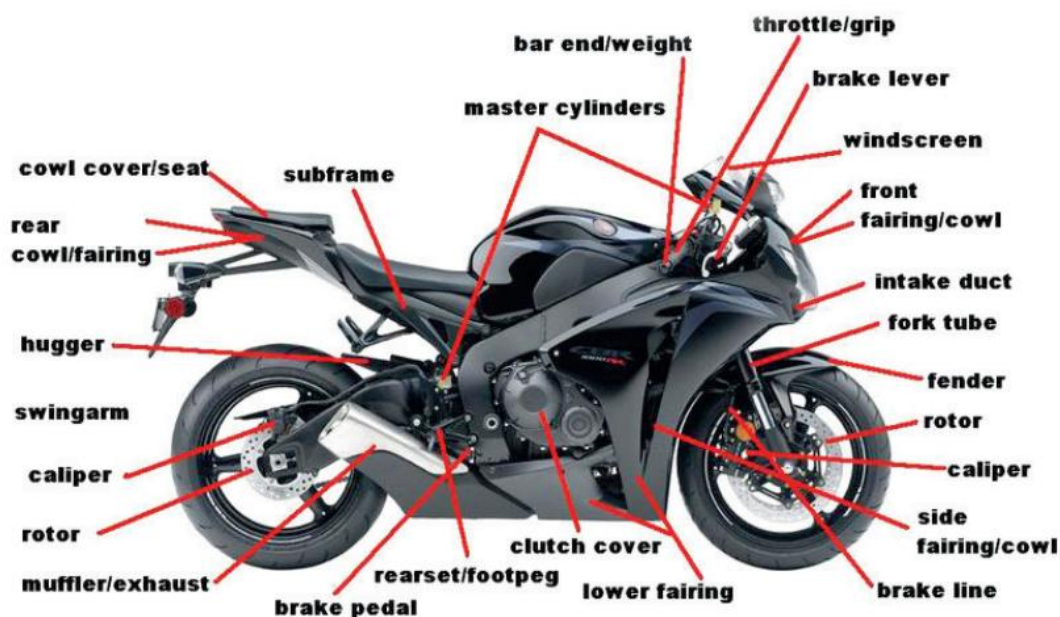

A two-wheeler's anatomy is generally split into the **Chassis** (structure), **Powertrain** (engine and transmission), and **Control Interface** (handlebars and pedals).

Main Parts of a Motorcycle

- **Handlebars:** The primary interface for steering, housing the **Throttle** (right), **Front Brake Lever** (right), and **Clutch Lever** (left).
- **Fuel Tank:** Positioned centrally for balance, it stores petrol.
- **Engine:** The "heart" of the bike, converting fuel to power.
- **Transmission:** Includes the **Gearbox** and **Drive Chain/Belt** that transfers power to the rear wheel.
- **Suspension:** Consists of **Front Forks** and **Rear Shock Absorbers** to maintain contact with the road.
- **Braking System:** Comprises **Brake Discs** or drums and **Calipers** for stopping power.
- **Exhaust Pipe:** Channels combustion gases away from the engine.
- **Chassis/Frame:** The structural skeleton that holds all other components together.

Four Wheeler

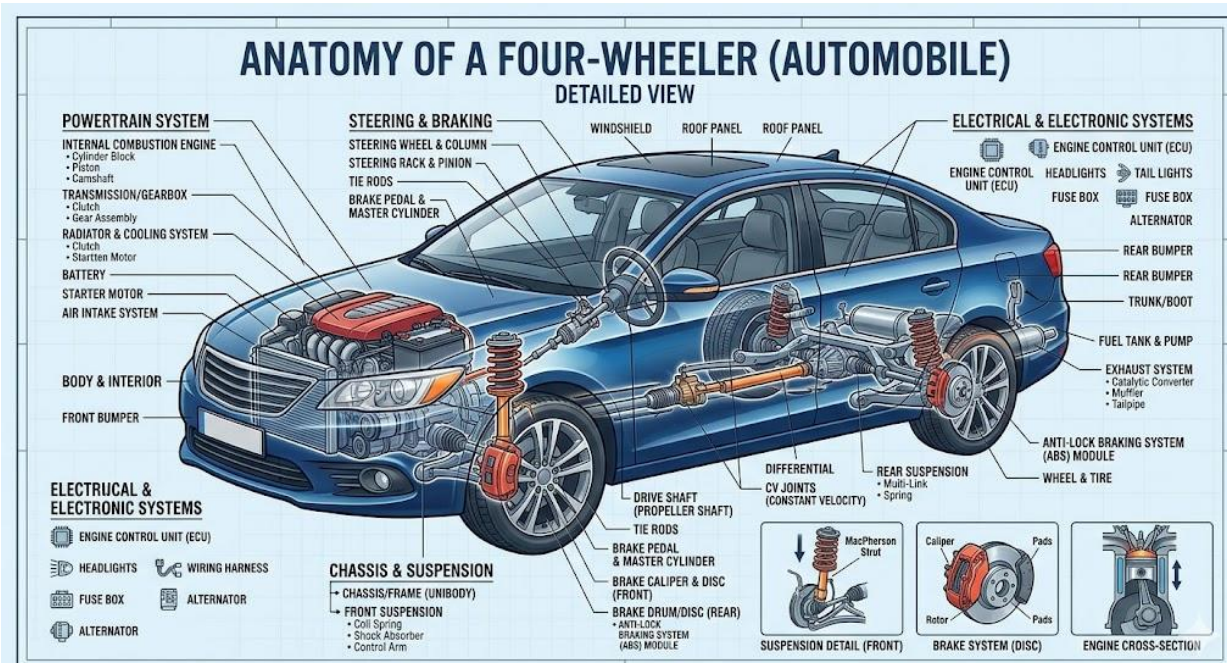

A four-wheeler's anatomy, specifically for a passenger car, is a sophisticated integration of thousands of parts. The structure is generally categorized into the Exterior/Body, Chassis/Frame, and Powertrain.

1. Structural & Exterior Anatomy

The body forms the visible outer shell and protects passengers.

- **Front End:** Includes the Hood (Bonnet), Front Bumper, Grill, and Headlights.
- **Greenhouse/Glass:** Comprises the Windshield, Side Windows, and Rear Window.
- **Rear End:** Includes the Trunk (Boot), Rear Bumper, and Tail Lights.
- **Structural Panels:** Key components include Fenders (around wheels), Quarter Panels (rear sides), and Pillars (structural supports between windows).

2. The Chassis (Under the Body)

The chassis is the vehicle's structural backbone, holding all mechanical systems.

- **Suspension:** Consists of Shock Absorbers (Struts), Springs, and Control Arms to absorb road impact.
- **Braking System:** Features Brake Discs (Rotors) and Calipers (usually front) or Drum Brakes (often rear).
- **Steering:** Typically a Rack and Pinion system that links the steering wheel to the front tires.

3. Powertrain & Mechanicals

This system generates power and delivers it to the wheels.

- **Engine:** The core unit composed of the Cylinder Block, Cylinder Head, Pistons, and Crankshaft.
- **Transmission:** A gearbox (Manual or Automatic) that regulates power output.
- **Drivetrain:** Includes the Driveshaft, Differential (allows wheels to turn at different speeds), and Axles.
- **Auxiliaries:** The Radiator (cooling), Alternator (electrical power), and Battery (energy storage).

Unit V

Sales & Service Personnel Grooming and Ethics

Session I: Sales & Service Personnel Grooming and Professional Behaviour

Introduction

Professional grooming, body language, and workplace discipline are foundational to a successful sales and service team, as they directly impact customer trust, brand image, and employee confidence. A well-groomed and disciplined staff can improve customer satisfaction by over 30%, as customers often equate appearance with product quality and reliability.

PROFESSIONAL PRESENCE: OUR GROOMING STANDARD



IMMACULATE UNIFORM

Wear a clean, pressed uniform daily. Ensure all buttons are present and shoes are polished.



FLAWLESS PERSONAL HYGIENE

Daily bathing, brushed teeth, fresh breath, and deodorant are essential.



NEAT & NATURAL HAIR

Hair must be well-combed with natural colors only. Men's hair must be short; women's hair tied if beyond the shoulder.



POLISHED DETAILS

Keep nails trimmed and clean. Jewelry must be minimal (one ring, one watch). Makeup must be light and natural.



CONFIDENT POSTURE

Always stand and walk with a straight back. Never lean on walls or run in the lobby.

Grooming Standards

Grooming for sales and service personnel centers on looking neat, clean, and professional to make a positive first impression.

- **Personal Hygiene:** Daily showering, use of deodorant, and maintaining fresh breath are essential.
- **Hair & Facial Hair:** Hair should be clean and styled neatly. Men should maintain a clean-shaven look or keep beards and mustaches neatly trimmed.
- **Uniform/Attire:** Uniforms must be clean, well-ironed, and properly fitted. Shoes should be clean and polished.
- **Nails & Hands:** Nails must be kept short and clean.

- **Makeup & Accessories:** Makeup should be subtle and natural, with minimal jewelry (e.g., a simple ring or watch).
- **Scent:** Fragrances (cologne/perfume) should be used very sparingly or avoided, as they can be distracting or cause allergies.

Professional Body Language

Body language accounts for a significant portion of communication and can make customers feel welcome and comfortable.

- **Smile:** A genuine smile, particularly upon greeting, builds immediate rapport.
- **Eye Contact:** Maintaining steady eye contact shows engagement and active listening.
- **Posture:** Standing or sitting up straight with shoulders back conveys confidence and attentiveness.
- **Open Stance:** Keep arms uncrossed and hands out of pockets to appear approachable and honest.
- **Gestures:** Use open palm gestures to indicate transparency. Avoid fidgeting or unnecessary movement, which can imply nervousness.
- **Mirroring:** Subtly mimicking the customer's positive body language can build trust.



Workplace Discipline

Workplace discipline ensures consistency, safety, and productivity.

- **Punctuality:** Arriving on time for shifts and meetings is critical.
- **Conduct:** Avoid eating, chewing gum, or smoking in customer-facing areas.
- **Customer Interaction:** Be courteous, patient, and polite, even with difficult customers.
- **Professional Boundaries:** Avoid engaging in excessive personal conversations or using mobile devices for personal reasons during working hours.
- **Teamwork:** Collaborate effectively and share information, ensuring a supportive team environment.

Session II: Ethics in Sales and Service and Customer Dealing

Ethical Selling and Service

In an era defined by informed consumers and heightened expectations, ethical conduct in sales is a necessity. Sales ethics encompasses honesty, integrity, transparency, and respect- qualities that not only shape individual reputations but also build lasting trust and credibility for the organization.

However, the path to ethical sales is often filled with challenges. Take, for example, the case of Volkswagen's emissions scandal.



In September 2015, the Environmental Protection Agency (EPA) discovered that Volkswagen had installed software in its vehicles to cheat emissions tests, falsely advertising the cars as environmentally friendly when they were emitting far more pollutants than allowed by law. While the company's sales targets were met and exceeded, the ethical breach cost them billions in fines and lawsuits.

They chose an unethical path to achieve short term goals and are stuck with a broken reputation even today. This instance exemplifies the need to practice ethical selling.

What is sales ethics?

Sales ethics refers to the principles and moral standards that guide behavior and decision-making in the sales process. It emphasizes treating customers with fairness, honesty, and respect while striving to achieve business objectives. Ethical sales practices focus on building long-term trust and strong customer relationships, rather than chasing short-term wins.

Why is sales ethics important?

- Aids in building trust and credibility
- Enhances brand integrity
- Ethical culture encourages collaborative environment among sales teams
- Promotes better customer satisfaction
- Reduces legal and financial risks
- Leads to higher customer retention
- Leads to long term success and sustainable growth

What are the 6 principles of ethical selling?

1. **Be honest & transparent:** Be truthful about the features, limitations and pricing of your product and service. Customers value honesty and are more likely to come back if they know that they can trust you.
2. **Take consent & be respectful:** Ensure that you always take the customer's consent before using their data and take measures to store it safely.
3. **Guide, don't manipulate:** Avoid aggressive sales tactics, misinformation, or fear-based selling just to hit quota. Ethical salespeople guide rather than push, helping customers make informed decisions on their own terms.
4. **Maintain a care & value-first approach:** Keep your focus on providing value and not just closing deals. When you recommend a solution that's truly beneficial to the customer even if it means a smaller sale, you build credibility and long term loyalty.
5. **Practice accountability and integrity:** If something goes wrong, own it. Apologize, rectify the issue, and learn from the experience. Accountability on your side shows integrity and often turns unhappy customers into loyal ones.
6. **Honour commitments:** If you commit to something, always follow through. Customers come back to a brand that they know is reliable and true to their word.

Unit VI
Road Safety

Session I: Introduction and Importance of Road Safety

Introduction

All of you must have seen some road accident in which people lose their life. India has a very high number of accidents on the road. In recent years there is some improvement in this area. However, with rapid increase of vehicles on the road the traffic conditions are under a lot of pressure.

Therefore, road safety is one of the nation's most serious public health issues. It has an impact on everyone, whether you drive, walk or cycle. We should take care of ourselves and respect others on the road.



What is Road Safety?

Road safety refers to methods be adopted by everyone while using roads. These safety methods are meant for reducing the risk of accidents and injuries or casualties on the road. These rules must be followed by all users of roads including pedestrians, cyclists, and motorists, bus & truck drivers.

Safety methods also relate to the construction, layout of roads as well as traffic regulation systems. So, we can summarise that road safety involves various aspects including:

- The design of roads and highways
- Laws pertaining to traffic and vehicles
- Systems of traffic safety and control
- Driver education
- School student's education about road safety
- Mass education about road safety
- Traffic and road safety signs
- Vehicle design
- Motor vehicle safety inspection and maintenance.

Actually, it is not difficult to keep our roads safe. Imagine that everyone follows simple safety measures and traffic rules. In that situation there will not be any accidents.

Importance of Road Safety

Road safety is the prevention of road accidents and injuries through measures like following traffic laws, using safety gear, and maintaining vehicles. It is important because it protects lives, reduces injuries and fatalities.

Key facts

Approximately 1.19 million people die each year as a result of road traffic crashes.

Road traffic injuries are the leading cause of death for children and young adults aged 5–29 years.

92% of the world's fatalities on the roads occur in low- and middle-income countries, even though these countries have around 60% of the world's vehicles.

More than half of all road traffic deaths are among vulnerable road users, including pedestrians, cyclists and motorcyclists.

Road traffic crashes cost most countries 3% of their gross domestic product

The Disability Burden of Road Traffic Injuries

To understand the disability burden of road traffic injuries, the Global Road Safety Facility (GRSF) surveyed a representative sample of over 2,300 patients hospitalized for road traffic injuries in six developing countries: **Bangladesh, Cambodia, Ethiopia, Mexico, Ukraine, Zambia.**

Who is getting injured?

Gender

81% of those injured were male



Age

55% were between 18 and 34 years old

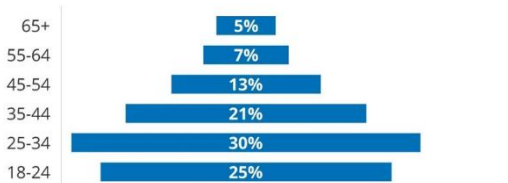

Type of road user

26% were pedestrians, and 35% were on motorcycles

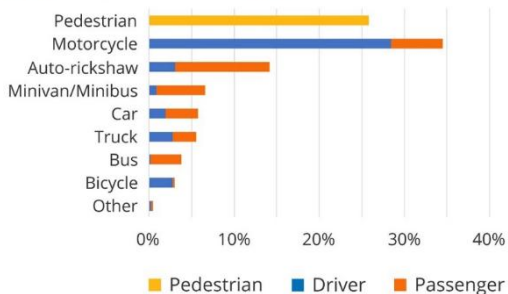

Care at scene and protective gear

44% did not receive care at the scene of the crash, and just 11% received care from ambulance staff or an EMT

81% of car occupants were not wearing seatbelts, 70% of motorcycle riders were not wearing helmets

The long, long road to recovery

Extent of injuries

Six months after hospital discharge, 21% were still suffering from severe or extreme difficulties, and only one quarter were injury-free



Slow return to normal life

Six months after hospital discharge, less than half had returned to their regular routines



Many studies have shown following major causes of road accidents are as follows:

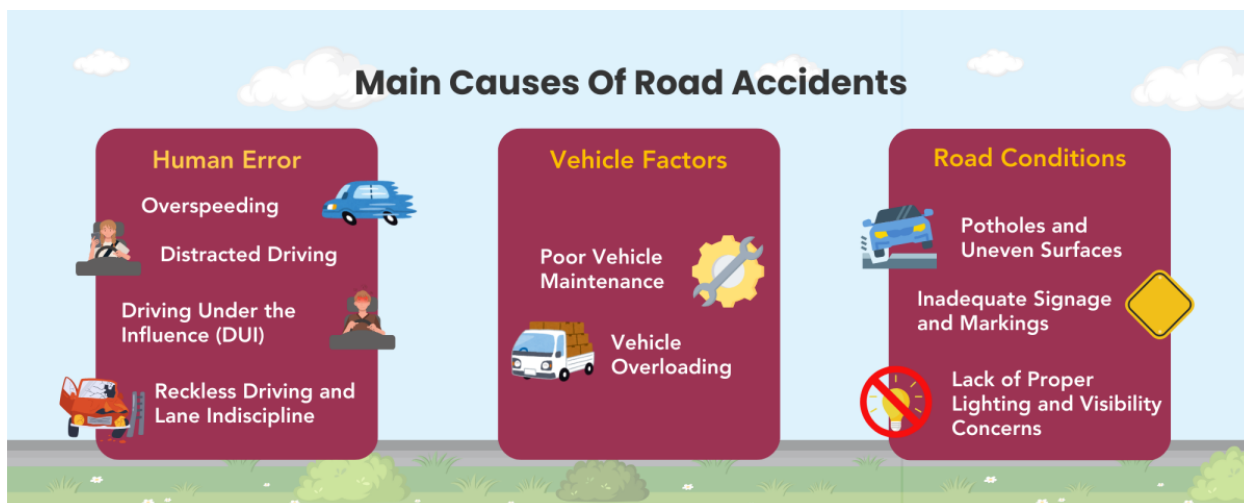

Road Safety Tips

Road safety is a result of contributing efforts from all the sectors of the society including both civilians and Govt. officials. In addition to the human sufferings, the estimated costs of the road injuries are a noticeable amount in GNP per annum. So, some tips can be fruitful in this direction.

Few important Road Safety Tips are mentioned below:

- Don't use your mobile phone whilst driving.
- Use belt in the back seat also.
- Don't drink and drive.
- Always adhere to speed limits.
- Take special care about children, senior citizens and pedestrians.
- Don't drive if tired.
- Pedestrians should walk cautiously and always cross the road through Zebra crossing.
- Always observe and anticipate actions by other road users.
- Keep your distances and always wear helmets and seat belts.

Safety Devices



Session II: Key Road Safety Principles and Safe Driving Techniques

Road Safety Principles for Drivers

Road Safety Rules

The infographic is titled "Road Safety Rules" and is organized into three rows of circular icons, each with a corresponding text label below it. The first row contains five icons: a traffic light character holding a stop sign, a car dashboard, a driver wearing a seatbelt, a person on a scooter wearing a helmet, and a driver looking at a smartphone. The second row contains four icons: a driver drinking alcohol, a driver yielding to a pedestrian, a car with a turn signal indicator, and a car driving in rain. The third row contains four icons: a car with various traffic signs, a driver with a sleeping head, a "SCHOOL ZONE" sign, and a car being maintained in a garage.

- Obey Traffic Signals and Signs
- Respect Speed Limits
- Wear Seatbelts
- Use Helmets
- Avoid Distractions
- Never Drink and Drive
- Give Right of Way
- Use Turn Signals
- Adapt to Weather Conditions
- Be Visible
- Stay Alert and Focused
- Obey School Zone Rules
- Properly Maintain Your Vehicle

Safe Driving Techniques

- **Stay Focused:** Keep your attention on the road and avoid distractions.
- **Safe Following Distance:** Maintain a reasonable distance between your vehicle and the vehicle in front of you.
- **Use Turn Signals:** Give other drivers a clear indication of your intentions.
- **Obey Speed Limits:** Observing speed limits can prevent accidents caused by excessive speed.
- **Scan for Hazards:** Continuously scan the road for potential hazards.
- **Avoid Aggressive Driving:** Be calm and in control of your emotions while driving.
- **Weather Awareness:** Make adjustments to your driving based on the weather.
- **Adapt to Traffic:** Maintain a flexible approach and adapt to changing traffic conditions.
- **Understand Right of Way:** Ensure that right-of-way rules are followed to prevent collisions.
- **Vehicle Maintenance:** Keep your car well-maintained to avoid breakdowns.

Unit VII

Workshop layout, Tools & Equipment

Session I: Workshop Layout

Workshop Layout

To optimize an automotive workshop, separate the space into customer-facing areas (reception/lounge) and operational zones (repair bays, storage, admin). Position service bays along one side with central pathways for vehicle movement. Place diagnostic equipment near bays and keep storage adjacent to workstations. Ensure safety zones are clearly marked, and keep heavy equipment away from customer areas to manage noise and hazards.

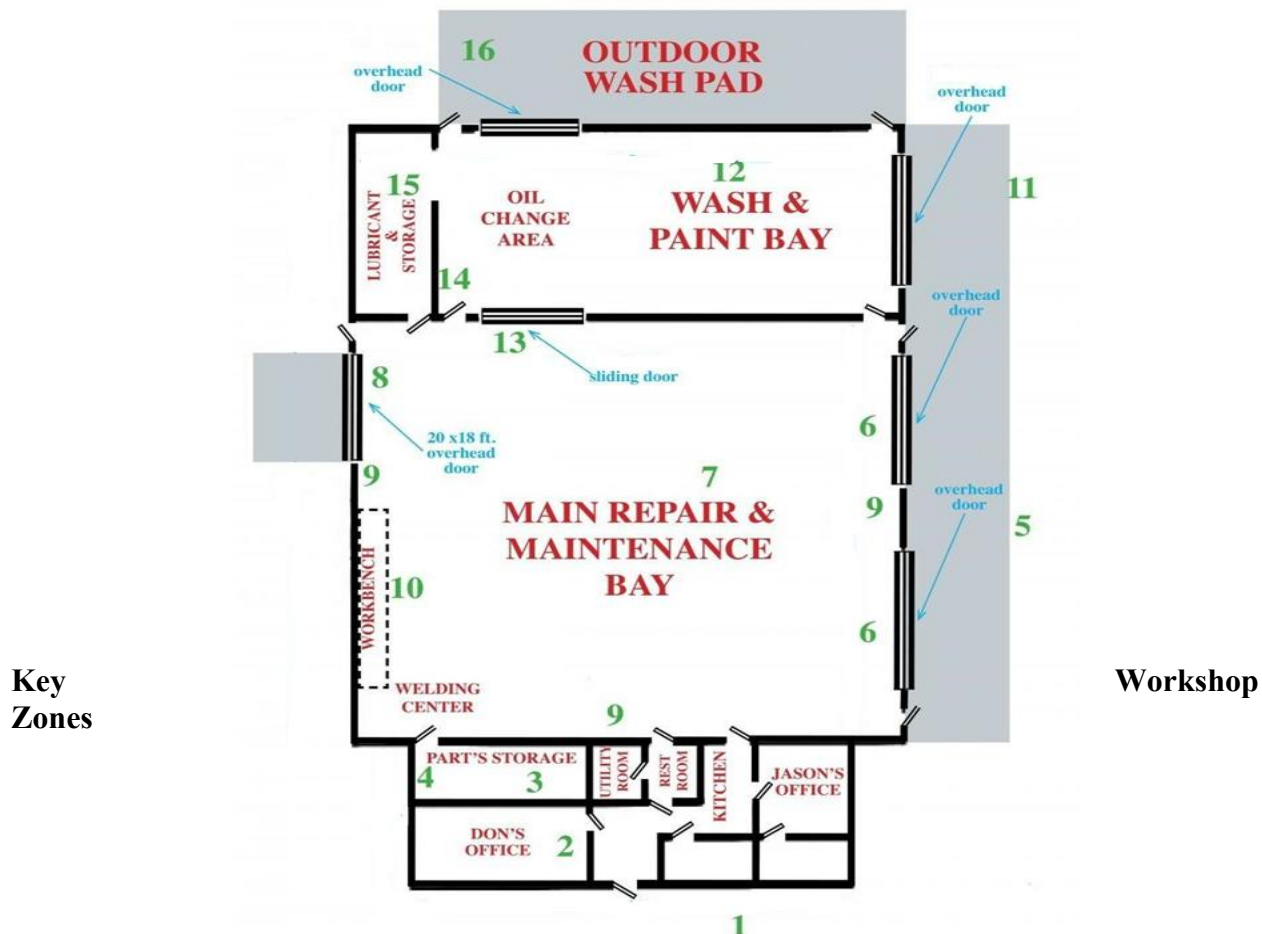

- **Customer Area:** Includes a reception and waiting lounge, ideally placed at the entrance for convenience and visibility.
- **Service & Inspection Bays:** The core of the workshop. Include general service bays and specialized inspection bays (using pits or lifts). Lifts should be positioned to allow full access around the vehicle without obstructing traffic.
- **Storage & Parts:** Racking for engines, transmissions, and fluids should be organized for easy access. Keep tools on wheels where possible for flexibility.
- **Administrative/Support:** Management offices, training rooms, or break areas are often separated or located on a second floor to keep them independent from the main floor noise.

Session II: Workshop Tools & Equipment

Introduction

As you know that that we require tools and equipment for servicing of a vehicle. Tools and equipment are used for repair and maintenance of any vehicle. Tools are made of different material as per strength, work and use. It can be easily handled and operated by any mechanic. Every vehicle has tools for emergency work as spare parts. The important tools used in automobile shops are general, electrical, special type.

Every tool has specific work and it is used in that way; Proper tools should be used for better efficiency. Generally, every tool has various size and shapes. Tools should be properly handled and kept in their position. Tools should be regularly cleaned and washed at specific duration.

In this session, you will develop an understanding of the tools such as general, electrical, special and workshop machine used at automobile workshop.

Manually Used Tools

Wrenches:

The objective of a wrench is to tighten or loosen bolt or nut. Based on fastener's design and size, appropriate wrench needs to be selected. It can also depend on how difficult the fastener is to reach.

Tip: - When using a wrench, pull it toward you rather than pushing it away as it provides better control and injury can be avoided during slip process.

Different types of wrenches are available: Box end, Open end, Combination, Adjustable, Socket and Allen.



Screwdriver:

Screwdriver is mainly used for tightening or losing screws by inserting it into the screw head. It helps in amplifying user's hand motion to its tip. There are various types of screwdriver tips based on specific requirement out which two most common head of screwdriver are straight or minus one and x shaped which is also called start tip. Handle of screwdriver made up of either plastic or wooden. For having better grip on handle rubber cover is also used on it. Some other tips are also used for various purposes like hourglass shape, square shape, six slots tips etc.



Pliers:

The primary purpose of the tool known as pliers is to grip objects firmly. The objects can then be turned, bent, or otherwise manipulated. Pliers have parallel handles, a pivot where the handles join, and parallel jaws that grasp the object. Special-use pliers may have additional components and purposes, such as cutting pliers. Types of pliers include engineer's pliers for gripping metal, flat-nosed pliers for grasping smaller objects, electrician's pliers for gripping electrical wires, and round-nosed pliers for bending wire into loops. The most common are slip-joint and plumber's

pliers, both with slip-joint adjustments to change the width of the jaw grip. In addition, locking pliers, sometimes known by the Vice-Grip brand name, are popular for firmly holding objects.

Socket-Set:

Socket set is having a number of different size detachable sockets used with socket wrench. It is basically a type of wrench having facility to attach a required size of socket at the end to turn a fastener.

The most common type of socket wrench is ratcheting socket wrench which is also called ratchet.

Extension bar-set:

It has number of bars in sets. Use extension bars to prevent over-tightening of lug nuts, distortion of wheels, drums and rotors. It helps to reach the bolt that are out of reach, so it makes easier for mechanic to take off the part deep in engine bay.

Torque-Wrench:

It is a tool which is used to exactly apply specific torque to a fastener like nut or bolts. Basically, it is a socket wrench having special internal mechanism.

Vice:

A vice is an apparatus used to hold an object so that required work can be carried out on object. Vice consists of parallel jaws. One of the jaws is fixed on the structure whereas another one is movable having a liver to move the jaws. Vices can be used to hold metal in place to be cut or modified.

Hacksaw:

A hacksaw is a metal-framed saw used primarily for cutting plastic and metal pipes and other small household materials. It is basically a U-shaped bended frame which can hold a thin wide metallic blade between its clip having a handle at one end made up of plastic or wood. Some hacksaw is also having facility for adjustment so that it can accommodate wide variety and size of blades as per requirement. As per the requirement of cut the metallic blades will have varied number of teeth per inches like 14, 18, 24 or 32. For cutting smaller objects dense teeth will be required. There are two types of hacksaw blades namely high carbon steel blades and high-speed steel blades used for various types of cutting job.

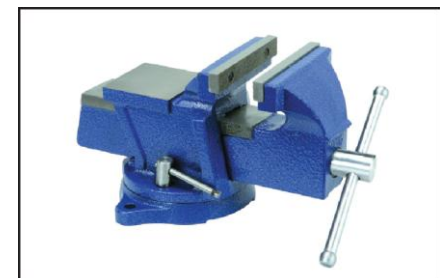

Chisels/Punches chisels:

Type of tool is having a typical shaped cutting of blade at one end used for carving or hard material cutting like wood, stone or even metal using hand and further struck with a mallet or mechanical power. In some chisel handle and blade are made up of metal or wood having a sharp edge. Chisels are various uses in service and maintenance.

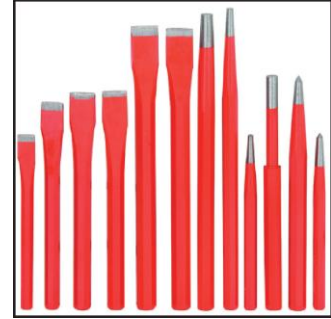
**Punches**

There are two distinct types of punches either hollow or solid one.

- Hollow punches are mainly used puncturing surface to create a hole of metal sheet or leather. We can identify hollow punches by looking towards the working end where we can find its exit hole which helps in removing and discarding punch material. Shape and size of working edge can vary and depends on the hole required and the material being pierced.
- Solid punches are made of metal and looks like a rod, designed to be struck by a hammer. It is mainly used to move objects such as pins or to form impressions on a work piece. Solid punches can vary in diameter, length and tip depending on the job to be performed.

Ball-Peen hammers:

The ball peen hammer is a type of peening hammer having 2 ends. Shape of the first end is like an ordinary hammer head while the other is ball shaped. It has a handle that is like that of a regular hammer and the material can vary, which includes wood, metal or fibre glass. This type of hammer is also called machinist's or engineer's hammer. It is the tool that is utilized to form the general shape of the material in metal fabrication. It is also used for hitting chisels and punches.

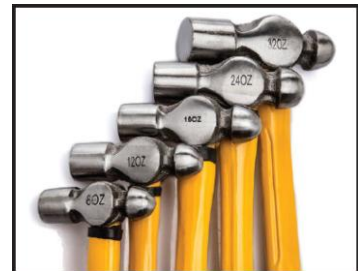
**Hand-Sledge:**

In this type of tool, a large flat metal head is attached to a handle which is also called lever. The advantage of sledge hammer is that its head size applies more force compare to other hammer of same size. It distributes force over a wide area along with mallet and basically the alternative of other types of hammers which apply force on relatively smaller area.

**Rubber-Mallet:**

Rubber mallets are much lighter and cheaper than metal mallets and are much safer to use. A rubber mallet is the basically used to produce the effect of hitting on another object. Sometime it is also used metal dent removal process because they don't leave any marks. They are also used in construction to force tight fitting parts together.

**Threader-Kit:**

Threader - kit has a number of threading tools. It is use to threading the bolt. If your threads are not completely destroyed, you can try "chasing" the threads with a thread chasing tap. This may

realign the threads so that the bolt can be threaded in place. A thread chaser is essentially a slightly undersized tap that will clean threads without removing any metal. When thread damage is too severe to be saved with a thread chaser, they can completely restore the threads with new coil-type thread inserts. They will provide a completely new threaded hole (with strong steel threads) that accepts the original size bolt. They are installed by drilling the damaged thread hole slightly oversize, tapping it with a larger tap, and screwing in the new thread insert coil.



Electrically Operated Tools

These tools are operated by electrical power

Drill:

It is a tool which is getting attached with cutting tool or driving tool. It is basically used for boring holes in various types of materials or also in fastening various materials by the use of fasteners using a drill bit or drive bit.

Drills are mainly used for boring holes in wooden, metal job and also in construction and some basic requirement at home. For drilling holes in various types of work like wooden, plastic or metal we use drilling machine. For safe drilling of such material bench drill is bolted down.

There are also some larger versions of drill called pillar drill having longer column which help them to stand on the floor. It functions the same as the bench drill but can drill larger pieces of material.



Drill-Bits:

Drill bits are cutting tools used to remove material to create holes, almost always of circular cross-section. Drill bits are available in various shapes which can be used to create different types of holes in various types of materials. For making a hole, drill bits have to be attached with drill machine. Drill machine provide power to drill bits so that it can cut through the work piece by rotation. Upper end of the drill which is also called shank is grasped in the chuck.



Reamers:

It is a type of rotating cutting tool used in metal work. It is designed to enlarge pre-existing hole dimension or further deepening by a small amount but with very high level of accuracy. Various types of reamers are available based on material used, style of flute styles and size.



The typical reamer is a rotary cutting tools designed to machine a previously formed hole to an exact diameter with a smooth finish. But other types are used to remove burrs from the inside of pipes & drilled holes and to enlarge and align holes for fasteners.

Soldering-Iron:

Soldering iron is a handheld tool used for soldering purpose. It melts the solder by applying heat so that solder can flow in-between joints of two work piece so that it can be joined.

A soldering iron consists of metal tip having heating facility and insulated handle. Metal tip heating is done by the use of electric current which is supplied using an electric cable through the heating element. Soldering irons are mainly used in electronics assembly during installation and repair work.

**Soldering gun:**

Soldering gun is a tool which works on electricity. It is used for metal soldering by using tin-based material so that a strong mechanical bond with good electrical contact can be achieved. The shape of a soldering gun is similar to that of a pistol.

**Pneumatically Operated Tools**

These tools are operated by compressed air.

Impact-Wrench:

Impact wrench is also called by various names such as impact gun, air gun, rattle gun, torque gun etc. Impact wrench is a socket wrench power tool used to deliver high output torque with minimum effort by user as it stores the energy in a rotating mass and delivers it suddenly to the output shaft.

**Measuring Tools****Gauge:**

Gauge is a measuring tool used for measurement to display certain information like time, pressure, dimension etc. Based on the use of gauge it can be generally defined as a physical quantity measuring device for example deciding the thickness, space gap, material diameter or flow pressure.

**Feeler-gauge:**

A feeler gauge is a tool used to measure gap widths. Feeler gauges are mostly used to measure the clearance between two parts. They consist of a number of small lengths of steel of different thicknesses with measurements marked on each piece. To use it, hold the feeler gauge the same

way you would hold a pen knife or a multi-tool, between your thumb and forefinger. If needed, feeler gauge blades can be stacked together to obtain the correct size for measuring.



Calipers:

Caliper is a measuring tool used to measure the distance between two opposite sides of an object. It is as simple as compass with inward and outward facing points. To use it, slide the jaws open, place the caliper over the object to be measured, and slide the jaws until they contact the workpiece. Read the measurement.



Dividers:

Divider is a measuring tool used primarily to measure distance particularly in maps. It is very similar to drawing compass except that compass is having one metallic point and one pencils whereas divider is having two metallic points.



Vernier caliper:

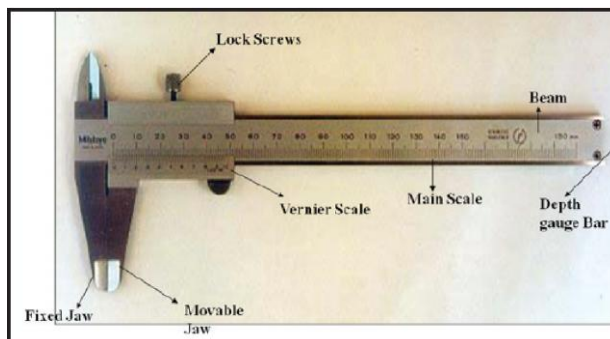

It is widely used for precision measurement of length, thickness and depth apart from inside and outside diameter. A vernier caliper has a main scale (in millimetres) and a sliding or rotating vernier scale. In figure 1 below, the vernier scale (below) is divided into 10 equal divisions and thus the least count of the instrument is 0.1 mm. Both the main scale and the vernier scale readings are taken into account while making a measurement. The main scale reading is the first reading on the main scale immediately to the left of the zero of the vernier scale (3 mm), while the vernier scale reading is the mark on the vernier scale which exactly coincides with a mark on the main scale (0.7 mm). The reading is therefore 3.7 mm.

Least Count: The smallest reading which can be accurately measured with a vernier caliper is called its least count (L.C), it is also known as vernier constant.

Calculation= Smallest division over main scale/Division over Vernier scale

= $1/20=0.05$ mm (It may be different in different in different calipers)

Vernier Calipers are available for measuring accuracy of 0.01- 0.02 or 0.5.

Zero error

Close the jaws to check the Zero error and calculate the zero correction. It is positive if showing some reading and to be deducted from the calculated value. If reading is less than zero it is negative and to be added.

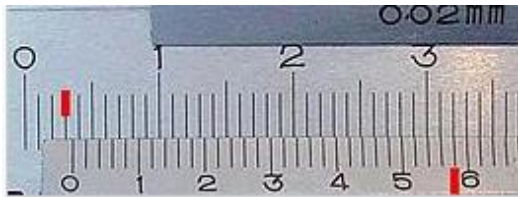

Fig: Reading Vernier scale

Measurement=Main scale reading + Vernier reading x Least count (adjust zero error in calculated value to find out final reading)

Reading Vernier (mm)

Least count - $1/50=0.02$ mm

Main scale reading - 3.00 mm

Vernier scale reading - $(5 \times 5 + 4 = 29) \times 0.02 = 0.58$

Total reading = Main scale + Vernier = $3.00 + 0.58 = 3.58$ mm

Micrometer:

Micrometer is basically a measuring tool used to measure block thickness, depth of slot, inner and outer diameter of shaft with high level of accuracy. It incorporates a calibrated screw widely used for accurate measurement of components.

A micrometer reading is not accurate if the thimble is over- or under-torqued. A useful feature of many micrometers is the inclusion of a torque-limiting device on the thimble—either a spring-loaded ratchet or a friction sleeve.

To take a measurement on the micrometer the object is gently pinched between the anvil and spindle. Once a very gentle pinch has occurred the user twists the ratchet until it clicks once or twice. This ensures that the right amount of tension is applied. The object should be held firm enough to not fall out of the micrometer under its own weight yet gentle enough that it can easily slip away if grasped. If necessary, the user can apply the lock nut to prevent the spindle from tightening or loosening while interpreting the measurement.

The user then looks at the lines on the spindle and finds which markings are aligned with the datum line. This line, highlighted with the red arrow in Figure, is the measurement.

Least Count of Micrometer:

LC = Pitch / Number of vernier scale division

LC = 0.5 mm / 50 or 1 mm / 100 = 0.01 mm

Zero error: When the anvil and spindle are touching the 0 line of sleeve (main scale) and the 0 line of thimble (rotating scale) must be aligned. If these are not aligned, the micro-meter is having zero error

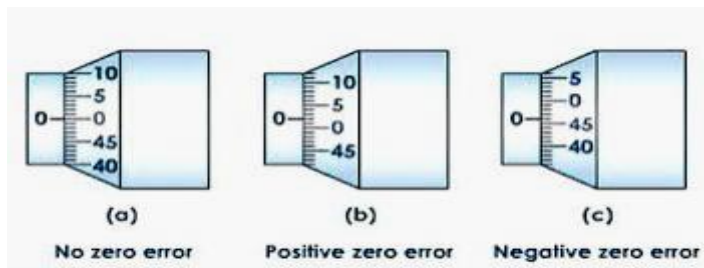
**Dial indicator:**

Dial indicator is mainly used in monitoring the readings as it helps in displaying small measurement changes in amplified form. The gradations measured with a dial indicator are small, typically 0.01 mm.

Dial indicator helps in checking the difference in tolerance thus very helpful in the process of inspection of mechanical part, measuring beam deflection or also in various other situations where a small measurement needs to be recorded.

To use it, rotate the outer dial to position the zero mark directly opposite the needle regardless of where it is pointing. Once the indicator is zeroed you can take the measurement by moving the part in question. The indicator will show movement either positive or negative.



The least count of dial indicator is 0.01 mm with a range of 0.80 mm or up to 2 mm. But some special type of lever dial gauge has the least count of 0.001mm with a range of 0 to 1 mm.

Zero out a dial indicator: Rotate the face of the indicator until the "0" marking aligns with the dial. Tighten the knob afterward to lock the face in position. Twist the zero adjustment knob if your dial indicator does not feature a rotating face. Continue twisting the knob until the dial aligns with the "0" marking.

Pressure / Vacuum Gauges

It is used to measure the pressure or the vacuum of liquid, gas, air etc.

Pressure Gauge:

A compression gauge or compression tester is a tool inserted into the spark plug hole on an engine while the flywheel is rotated. This will result in a pressure reading that can be used to judge the condition of a cylinder, piston and rings.



Compression Gauge:

A compression gauge or compression tester is a tool inserted into the spark plug hole on an engine while the flywheel is rotated. This will result in a pressure reading that can be used to judge the condition of a cylinder, piston and rings.



Electrical Quantity Measuring Devices

Voltmeter:

Voltmeter is a measuring instrument used to measure potential difference or voltage between two points in either electrical or electronic circuit. It is often called voltage meter. There are two types of voltmeters i.e.

- analog which is using needle type of pointer to show the reading whereas
- another type is digital which shows reading as numerical display.



A voltmeter in a circuit diagram is represented by the letter V in a circle.

Multi-meter:

Multimeter is an electronic measuring instrument which is also called as multi tester. It is equipped with the facility of measuring several functions within one unit. Multimeter is a hand-held device used to measure current, voltage both type AC and DC and resistance with high degree of accuracy and mainly used for fault finding during maintenance and service process. It is very helpful in electrical or electronic problem troubleshooting in a wide range of industrial and household devices such



as electronic equipment, domestic appliances, power supplies and wiring systems.

Diagnostic Tools and Equipment

These tools are used for diagnostic purpose or for doing some settings

Test light:

Test light is electronic test equipment also known as test lamp, voltage tester. It is basically used for establishing the presence or absence of alternating current in a piece of equipment under test condition.



Tachometer:

Tachometer is a measuring tool used to measure rotation speed of instrument shaft or disk in a motor or other such machine.



Scan-Tool:

Scan tool used in automotive is often called as scanner. This is basically an electronic tool which can be interfaced with vehicle for diagnostic purpose. It also helps to reprogram control module of vehicle.



Oscilloscope:

The oscilloscope helps us find the problem quicker and easier. Shows the electrical activity in the vehicles ignition system and other electrical systems.

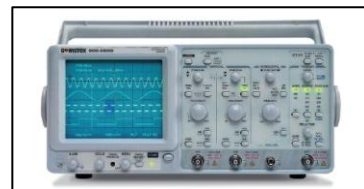

Exhaust gas analyzer:

Vehicle's exhaust is having various chemicals and to measure the amount of chemical exhaust gas analyzer is use. To measure the fuel-air ratio of the fuel mixture of an engine a carbon dioxide sensitive element device is placed in the exhaust manifold. It is also known as fuel-mixture indicator or smoke feeler.



Special Service Tools

Bearing puller

A bearing puller is a tool used to remove bearing sets from a rotating machine shaft or from a blind bearing hole. These tools are made of tool grade steel, so they are harder than the parts they are used on. They are usually hand-powered with a handle on the turn screw. Some bearing pullers are

hydraulically powered, using a hydraulically powered piston to press against the end of the shaft the bearing is on.

There are arms with extensions that allow the user to pull in the inner race as well. It is preferable to drive from the inner race since it is firmly set on the shaft, while the outer race is not very well secured to the rest of the bearing assembly.

Types

- **Bearing Splitter Plates:** Bearing splitter plates are the safest type of bearing pullers to use. Technically these are not pullers, but pushers, since they use wedges to push and pop the bearings off of the shaft. These consist of two half plates held together by two long, wide diameter, heavy duty screws with nuts on all four ends. The plates have a hole in the middle and are ground downwards towards the hole in the center, so as you tighten the two plates together on the outside, the tool wedges into and applies upward thrust on the inner race of the bearing. These work best if there is a gear or hub directly behind the bearing, so that the tool is held in place on one end as the upward thrust pushes on the inner bearing race.
- **Two and Three Arm Bearing Pullers:** These are the most common types of bearing pullers and can be used for pulling gears or bearings. The arms have fingers on the end that bend in to get behind the bearing to its race. The center screw of the puller is torqued so it pushes on the top of the shaft and upward thrust is applied to the bearing's race. Arms and fingers are interchangeable so the same puller can accommodate a wide variety of bearing and shaft sizes and lengths.
- **Internal Bearing Puller:** Internal bearing pullers are made to extract a bearing set, a bushing, or a simple bronze sleeve from a blind hole. Blind holes preclude using a punch to drive out the sleeve or bearing. Internal bearing pullers usually resemble small dent pullers since they have a slide hammer along the shaft to apply upward thrust and shock to the bearing. The collet, the part that goes into the bearing at the tip of the puller shaft, is expandable. The user can lock the collet inside the bearing or bushing, usually by spinning the collet tighter on the puller shaft. By working the slide hammer away from the bearing and up towards the user, the tool's hammer will transmit the upward thrust to the bushing and pull it out of its hole.

Clutch holder

Clutch holder is used to hold the inner clutch hub, which is necessary for removal and installation of the clutch hub and clutch basket of the vehicle. To use it place the jaws on the clutch hub so the ends fit into the square grooves where the drive plates (steel plates) would usually rest. Using the

adjusting bolt on the back of the tool, adjust the tension so the tool can apply light pressure on the hub when clamped down. With the clutch hub held in place the center nut can be removed with the appropriate wrench.

The tool can also be used to hold flywheels, gears, sprockets, and other parts with the appropriately sized “holding holes” for easier removal. The pins on the back of the jaws are used to fit into the “holding holes”. Simply use the jaw adjusting bolt to set the tool to fit the object you are holding. Once again there should only be light pressure used to clamp the tool to the object. Once in place you can hold the object and more easily remove or tighten the nut or bolt.

Tappet Adjuster

The hand tool allows micro adjustment without disturbing the locknut which can be tightened when the correct clearance is achieved. Use a knurled handle to ensure a secure grip and 12mm wrench to hold the locknut socket while using square type driver to loosen or tighten the valve adjustment screw.

Loosen the nut just enough to allow adjustment of the tappet. Turning the tappet clockwise with the screwdriver will decrease the clearance (counter-clockwise to increase clearance if clearance is too small).



Service Workshop Equipment

Modern service workshop deploy important workshop machine for handling and servicing of a vehicle. These machines make work very systematic and comfortable to mechanic. Common equipment fitted in the workshops are Two Post lift, Air compressor, Wheel balancer, Bench vice, Work tables, Bench grinder, Oil draining & Filling equipment, Cooling system tester, BC clamp meter, Coolant tester, Battery & Charging system tester (Megatronics), Diagnostic tool (genesis Evo), Pneumatic tools and many other tools. We will be discussing some equipment here. Whenever you visit any service centre, kindly see the working of these machines.

Two Post Lift

It is used for lifting an automobile vehicle and to carry out the work under the chassis. It consists of two columns and screws are fitted in each column. Similarly four post lift is also used in workshop.



Air compressor

This is the machine which is used to increase the pressure of air by reducing its volume.

Generally, air compressors have been categorized in two types:

- Rotary Screw Air Compressors
- Reciprocating Air Compressors

Rotary Screw Air Compressors

The rotary screw air compressor has become the most popular source of compressed air for industrial applications.

Reciprocating Air Compressors

Designed for heavy shop or industrial use, Ingersoll Rand Two Stage electric air compressors provide the quality and performance that are ideal for most applications and users, including automotive service and body shops, fleet maintenance, machine shops, production and manufacturing lines, car washes, maintenance/ repair shops and farms.

Wheel balancer

Wheel balancing helps in minimizing tire vibration and bounce. By wheel balancing traction, steering control improves and life of tires increases. Automatic wheel balancer is designed for the tyre shop and workshop. It is very simple and easy to operate.

Computerized wheel alignment machine

A computerized wheel alignment is a technology used for adjusting the angles of all four wheel to the car manufacturer basic specifications. It is a part of standard automobile maintenance procedure to reduce tire wear issue and to ensure the vehicle travels straight without pulling to any of one side.

Automatic AC gas charging machine



Automatic AC gas charging machines are specialized, fully automatic units designed for rapid, precise, and eco-friendly refrigerant recovery, recycling, and charging in automotive AC systems. They feature automatic vacuuming, oil injection, and leak testing, enhancing workshop efficiency.

Pneumatic wrenches

Pneumatic wrenches that is made from premium quality raw material. This type of wrenches are used for accuracy and easy operations, mostly in workshops, power plants, mining & cement industries, railways industries, fertilizers/ chemicals and so on. These are used where accurate torque is required on a nut and bolt. These wrenches are operated electrically.



Unit VIII

Automotive Technology & Routine Maintenance (Engine)

Session I: Engine and its Systems

Engine

An engine is a device that changes the energy from a fuel into mechanical energy, which in turn generates motion. In the case of cars, gasoline and diesel are the most common fuels used by engines, such as the ones that power them.

Engine is the heart of a vehicle, converting fuel into mechanical energy to power the car and its various systems. It's responsible for generating the force that moves the vehicle, operates accessories like air conditioning, and provides power to the electrical system.



How engine works

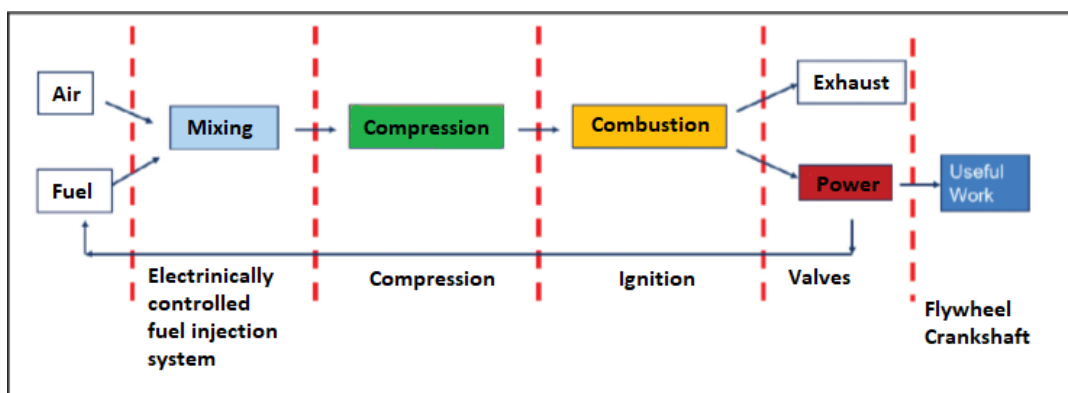

1. The engine takes in a mixture of fuel and air (gasoline) or only air supplied to the cylinder and fuel is injected in compressed and hot air.
2. The fuel-air mixture is compressed, creating a higher pressure and temperature.
3. In spark-ignition engines (like gasoline engines), a spark plug ignites the compressed mixture, causing it to burn rapidly. In compression-ignition engines (like diesel engines), the heat from compression ignites the fuel.
4. The burning fuel expands, pushing a piston down. This movement is transferred to the crankshaft, which converts the linear motion of the piston into rotational motion.
5. The exhaust valve opens, and the piston moves up, pushing out the burned gases.

The modern day car engine is a 4-stroke engine which means it creates usable power in 4 strokes. Each stroke is defined as the movement of the piston from the bottom most position (Bottom Dead Centre) to the topmost position (top dead centre) and vice-versa. The 4-strokes are as follows: Intake Stroke, Compression Stroke, Power Stroke, Exhaust Stroke. Here is a flowchart overview of the processes taking place from the start of the power cycle to the end:

Four Strokes of the Engine:

1. **Intake Stroke:** The intake stroke refers to how air and fuel or only air enter an engine's combustion chamber. The process behind this first step, however, varies by engine type. The piston moves down the cylinder while the intake valve draws an air and fuel mixture or only air into the combustion chamber.
2. **Compression Stroke:** The intake valve closes, sealing the combustion chamber. The crankshaft rotates to complete its first full revolution, and drives the piston upwards, compressing the fuel and air mixture.
3. **Power Stroke:** A spark plug ignites the air-fuel mixture or combustion initiates as soon as fuel is injected in compressed hot air, resulting combustion quickly expands the gases, forcing the piston back down the cylinder.
4. **Exhaust Stroke:** Finally, the exhaust valve opens, and the piston travels back up one last time, forcing the exhaust gas to leave the cylinder, while the piston applies a fresh coating of oil.

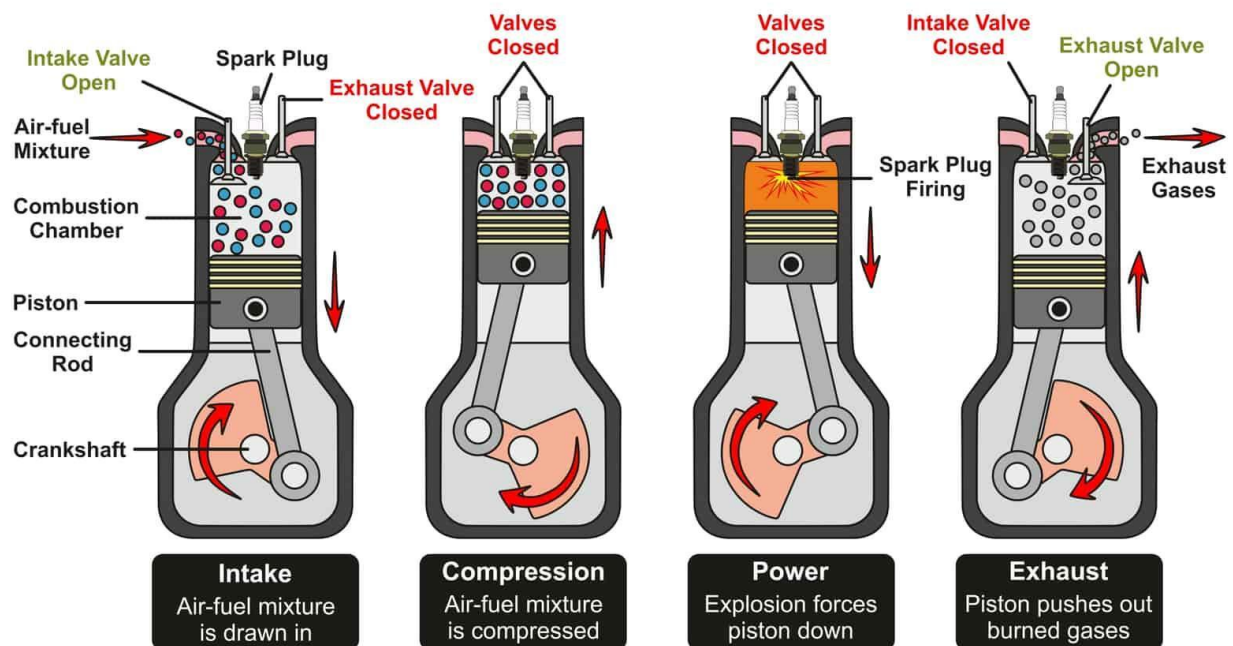

How Engine Runs the Vehicle

In this system engine power is transmitted to all four wheels to generate traction. The process involves the engine's power going through the transmission to a transfer case (in four-wheel drive vehicles), which distributes power to the front and rear axles. Differentials then send this power to each individual wheel, allowing them to turn at different speeds while maintaining grip.

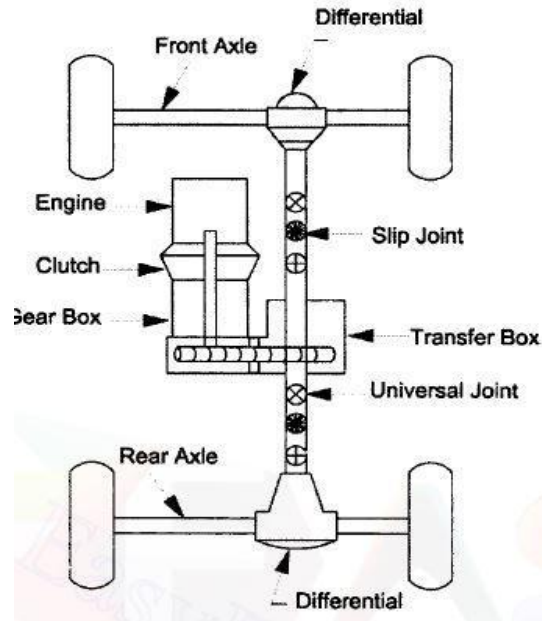

Technical terms used in engine:

Number of basic terms are used to describe and compare engines. A few commonly used terms are described here.

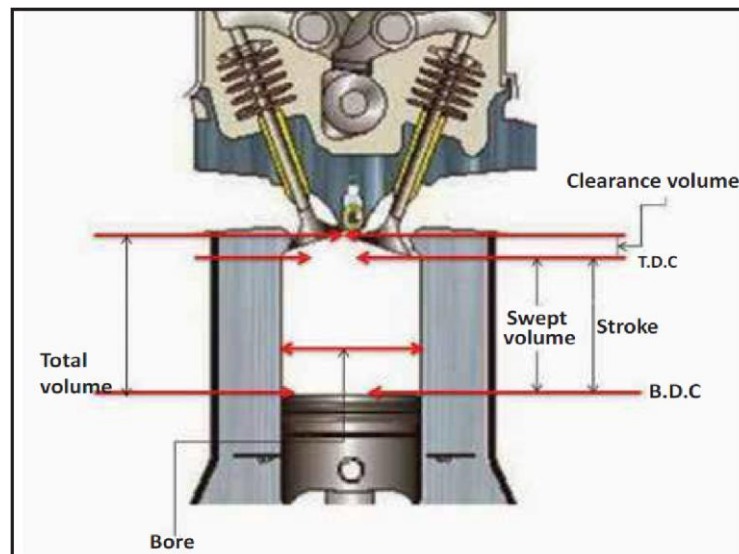

- **Top Dead Centre (T.D.C):** Extreme position of the piston at the top of the cylinder is referred as TDC.
- **Bottom Dead Centre (B.D.C):** Extreme position of the piston at the bottom of the cylinder is referred as BDC.
- **Bore:** Engine cylinder diameter is called as bore and measured in mm.
- **Stroke:** When the piston moves from TDC to BDC, the distance travelled by piston is referred to stroke. Measured in mm.
- **Swept volume:** Volume between TDC & BDC.

- **Clearance Volume:** Volume available above the piston, with the piston in top most position is referred as 'clearance volume' (V_c).
- **Piston Displacement:** The volume covered by piston while moving from TDC to BDC is called piston displacement, It is also referred as swept volume (V_s).
- **Engine Capacity:** It is the total displacement of piston or all the cylinders Swept volume. Measured in cubic centi-meter
- **Compression Ratio:** The degree to which the charge in the engine is compressed is indicated by compression ratio. The calculation of compression ratio is based the volume above the piston at BDC to the volume above the piston at T.D.C. If 'Y' is the compression ratio, then $Y = (V_s + V_c)/V_c$

For petrol engines, compression ratios are about 8 to 9.5 : 1, whereas for diesel engines, these vary from 16 to 22:1

- **Power:** It is the work done in a given period of time. Doing the same amount of work in a lesser time would require more power. The units of power are Kilo Watts (KW), HP, PS (Pferde Starke or the Metric HP unit)

$$1 \text{ KW} = 1.34 \text{ HP} \quad \text{or} \quad 1 \text{ HP} = 0.746 \text{ KW}$$

$$1 \text{ KW} = 1.36 \text{ PS}$$

- **Horse Power (H.P.):** This is the amount of energy required to do 4500kgm. of work in one minute.
- **Indicated Horse Power (I.H.P):** The power developed within the engine cylinders is called indicated horse power. This is calculated from the area of the engine indicator diagram.
- **Brake Horse Power (B.H.P):** This is the actual power delivered at the crankshaft. It is obtained by deducting various power losses in the engine from the indicated Horse Power.
- **Friction Horse Power (F.H.P.):** This is the power lost due to friction present between different mating components.

$$\text{F.H.P} = \text{I.H.P} - \text{B.H.P}$$

- **Engine Torque:** Is the turning force required to turn or twist any object. It is the force of rotation acting about the crankshaft axis at any given instant of time.

For example, the effort that is required to tighten bolt with a spanner is called torque.

$$\text{Torque} = \text{Force} \times \text{Radial Distance}$$

It is expressed in Newton - meter (Nm).

$$1 \text{ Kgf-m} = 9.8 \text{ N-m}$$

$$1 \text{ Kg-m} = 7 \text{ Lb-f (Pound-foot)}$$

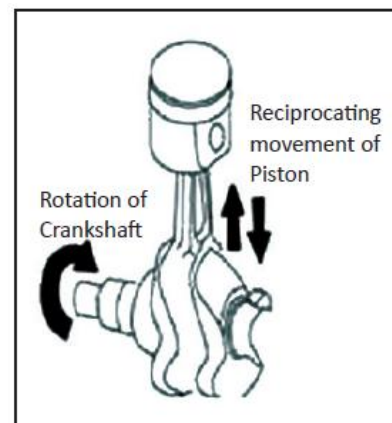

Core mechanical components

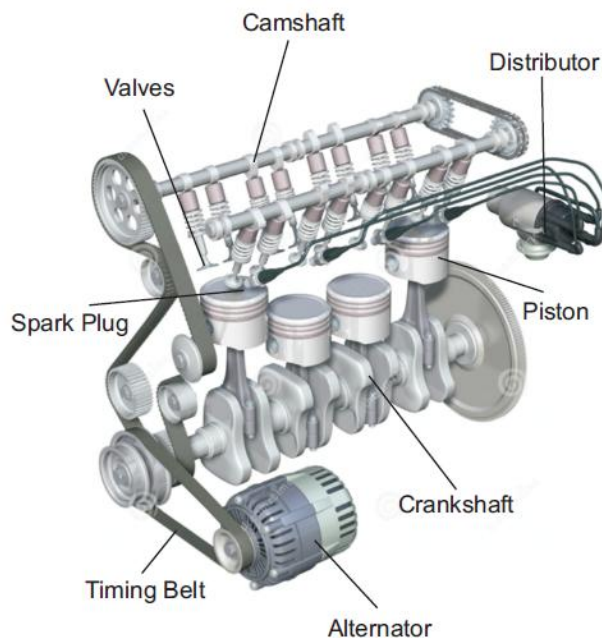

- **Engine Block:** The main body of the engine that houses the cylinders and other parts.
- **Cylinders:** The chambers where the combustion process takes place.
- **Pistons:** Move up and down inside the cylinders, pushed by the force of combustion.
- **Crankshaft:** Converts the up-and-down motion of the pistons into rotational motion, which ultimately turns the wheels.
- **Camshaft:** A rotating shaft with lobes that push on components like pushrods or directly on the rocker arms.
- **Rocker Arm:** A pivoting lever that receives motion from the camshaft (or pushrod) and translates it to push the valve open.
- **Inlet Valve:** Opens to allow the air-fuel mixture into the cylinder.
- **Exhaust Valve:** Opens to release burnt gases from the cylinder.
- **Connecting Rods:** Link the pistons to the crankshaft.
- **Spark plug:** A spark plug works by using high voltage to create a spark that ignites the compressed air-fuel mixture in an engine's cylinder.

Major engine systems and their functions

- **Fuel System:** Supplies a mixture of air and fuel to the cylinders. It includes the fuel tank, pump, and fuel injectors or a carburetor.

FUEL SUPPLY SYSTEM

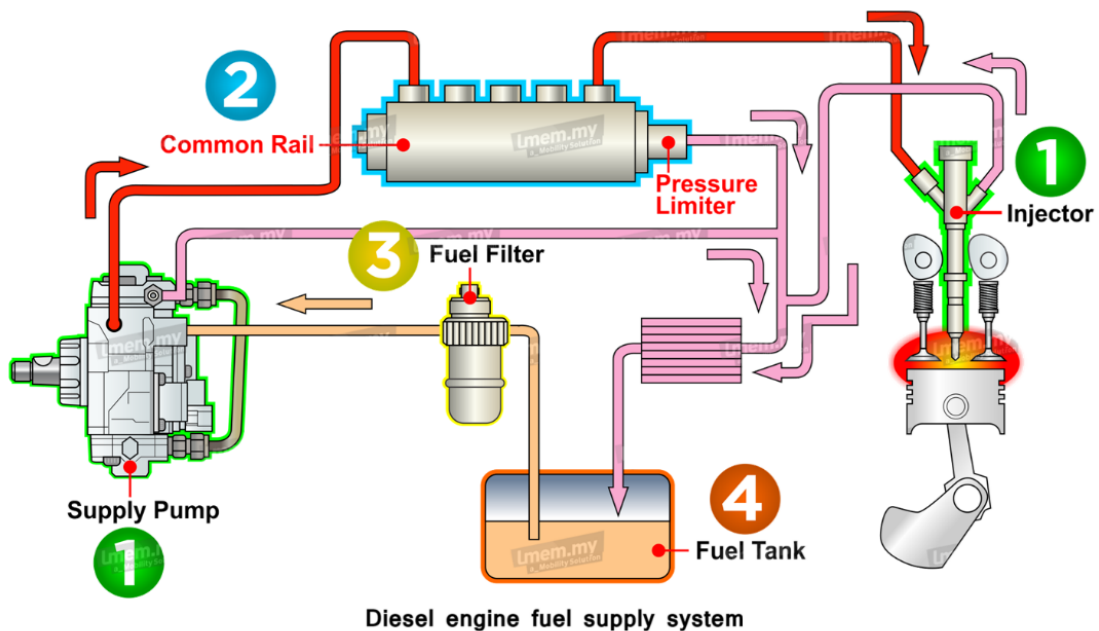
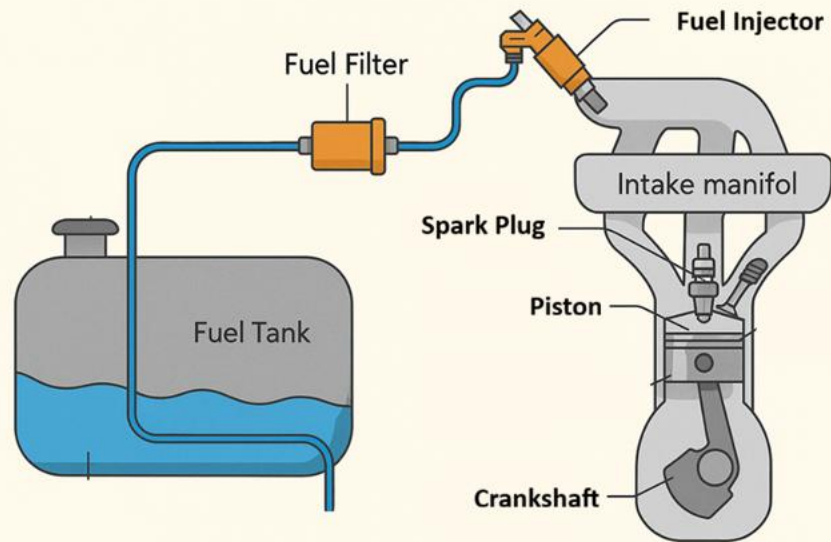

- Ignition System:** Provides the spark that ignites the air-fuel mixture in a gasoline engine. It includes the spark plugs and other components that generate a precisely timed electrical charge.

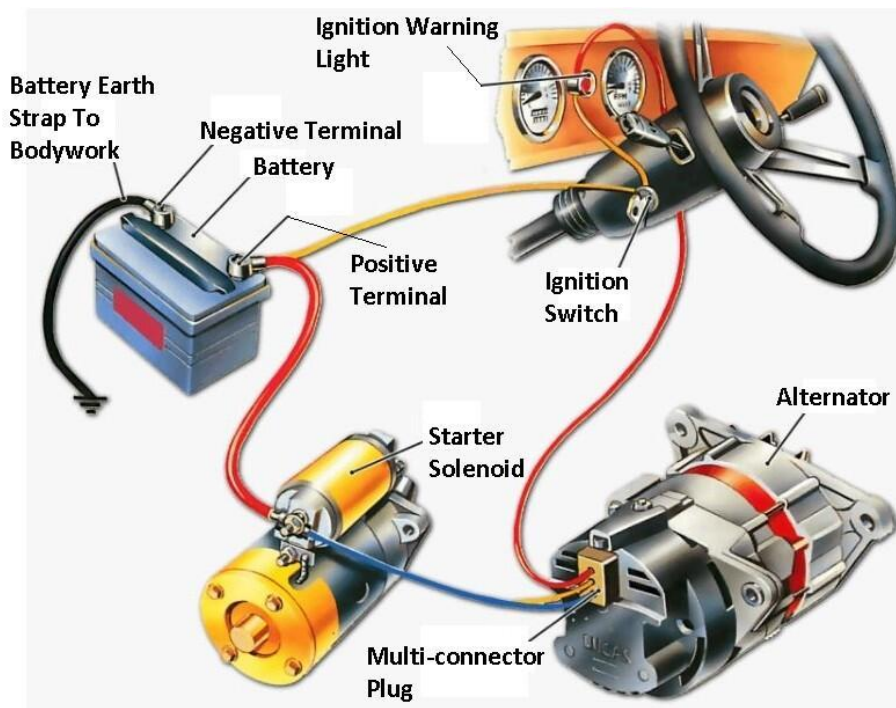
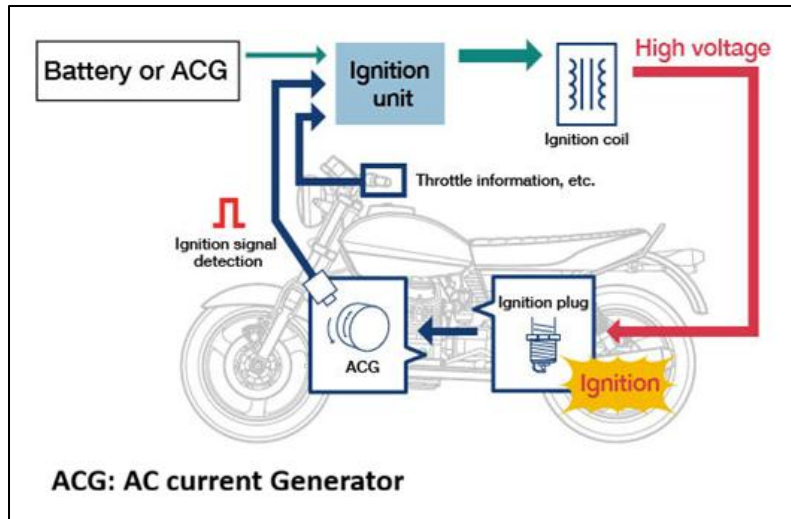

Ignition System

- **Cooling System:** Prevents the engine from overheating by circulating a coolant to absorb and dissipate heat, or by using airflow across cooling fins in air-cooled engines.

primary components of a typical automotive cooling system:

1. The Radiator: The radiator acts as a heat exchanger. It is located at the front of the vehicle to maximize airflow. Hot coolant from the engine flows through thin metal tubes, and as air passes over the attached fins, the heat is transferred from the liquid to the atmosphere.

2. Water Pump (Coolant Pump): The water pump is the "heart" of the system. Usually driven by a belt (serpentine or timing belt), it uses centrifugal force to circulate coolant throughout the engine block, cylinder heads, and radiator.

3. Thermostat: The thermostat is a heat-sensitive valve located between the engine and the radiator.

4. Cooling Fan: When the vehicle is stationary or moving slowly, the radiator doesn't receive enough natural airflow. The electric or engine-driven fan pulls air through the radiator fins to ensure heat exchange continues even at a standstill.

5. Radiator Pressure Cap: The cap is more than just a lid; it is a calibrated pressure valve. By maintaining pressure in the system, it raises the boiling point of the coolant, preventing the engine from "boiling over" under high-stress conditions.

6. Expansion Tank (Recovery Tank): As coolant heats up, it expands. This tank provides a reservoir for the expanding fluid to flow into, rather than leaking out of the system. Once the engine cools down, the resulting vacuum draws the coolant back into the radiator.

7. Coolant (Antifreeze): While not a mechanical "part," the fluid is a critical component. Usually a 50/50 mix of ethylene glycol and distilled water, it prevents the engine from freezing in winter, boiling in summer, and protects internal metal parts from corrosion and scale buildup.

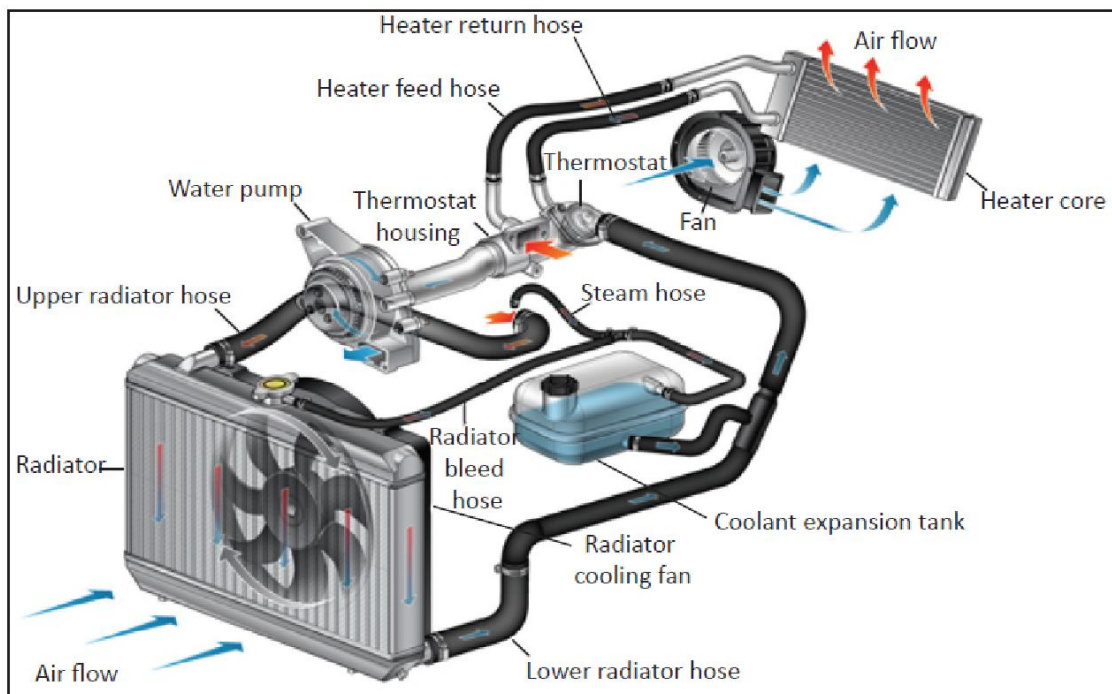

- **Lubrication System:** Circulates oil to reduce friction between moving parts, which helps cool the engine and prevents wear.

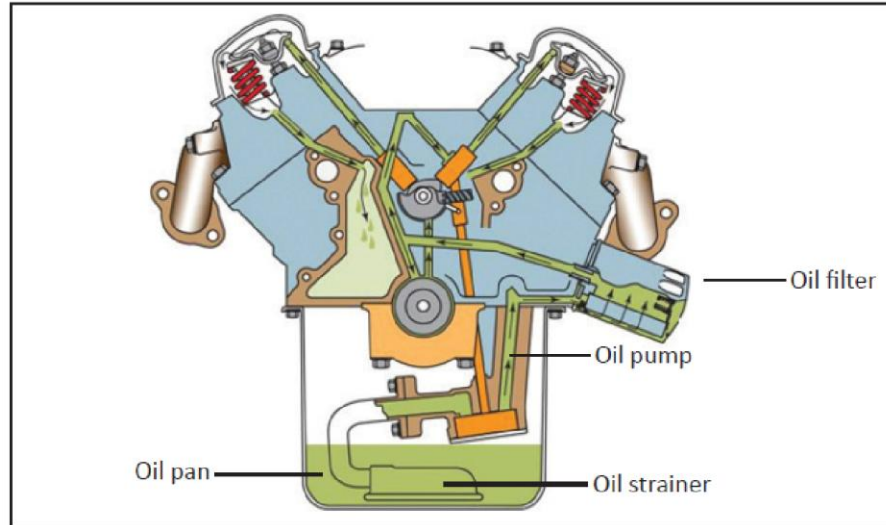

- **Exhaust System:** Collects and directs exhaust gases away from the engine. It includes the exhaust manifold, which gathers the gases from the cylinders.
- **Catalytic converter:** It is an exhaust emission control device that uses catalysts like platinum, palladium, and rhodium to convert toxic gases from an internal combustion engine into less harmful substances like carbon dioxide, nitrogen, and water. They are a vital part of a car's exhaust system, designed to reduce pollution by facilitating chemical reactions that convert pollutants like carbon monoxide, hydrocarbons, and nitrogen oxides into safer gases.
- **Intake System:** Draws clean air into the engine for combustion. It typically includes an air filter to remove dirt and debris.

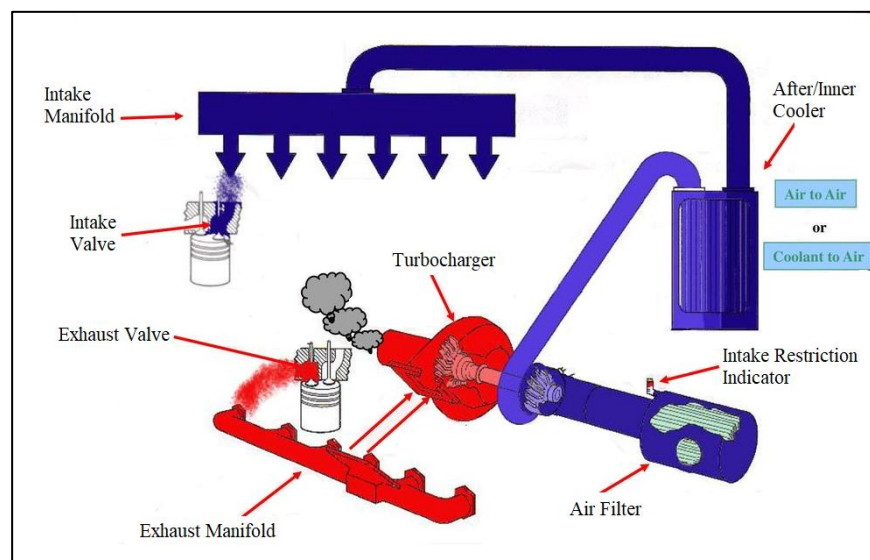

Types of

Engines

The Indian automotive industry offers various types of car engines to suit the diverse needs of drivers, whether it's performance, affordability, or environmental impact. Each engine type has

unique advantages and mechanisms, from traditional petrol and diesel engines to advanced turbocharged, hybrid, and fully electric systems.

Here is a look at the various car engine types found in India:

1. Petrol Engines

Petrol engines are widely used in India, especially in hatchbacks, sedans, and compact SUVs. These engines ignite a mixture of air and fuel using spark plugs, which drive the pistons and power the vehicle.

Key Features:

- Work more quietly and smoothly, resulting in lower amounts of noise, vibration, and harshness.
- Deliver consistent power across a broad range of RPM.

Advantages and Disadvantages of Petrol Engine:

Advantages	Disadvantages
Lower initial cost of purchasing the car.	Higher fuel consumption compared to diesel engines.
Ideal for city driving and short daily commutes.	Long-term running costs increase due to rising fuel prices.

2. Diesel Engines

Diesel engines are ideal for long-distance travel and utility vehicles thanks to their superior fuel efficiency and higher torque output. This makes them well-suited for highway driving, towing, and heavy loads. While they may cost more upfront, their long-term savings and durability often compensate for it.

Key Features:

- Diesel engines don't rely on spark plugs. Instead, they use compression ignition to power the vehicle.
- They generate strong torque and perform best at low RPMs, making them ideal for heavy-duty tasks and efficient cruising.

Advantages and Disadvantages of Diesel Engine:

Advantages	Disadvantages
Delivers better mileage than petrol engines.	Higher levels of noise and vibrations.

Ideal for highway driving and transporting heavy loads.	The initial cost of purchase is higher compared to petrol-engine cars.
---	--

3. Naturally Aspirated Engines

Naturally aspirated (NA) engines are internal combustion engines that rely on atmospheric pressure to draw air into the cylinders, rather than using a turbo or supercharger. They're known for their smooth, linear power delivery and simpler design, which makes them easier to maintain.

Key Features:

- Simple to assemble with fewer components.
- Naturally aspirated engines allow air to flow into the cylinders automatically as the piston moves downward.

Advantages and Disadvantages of Naturally Aspirated Engine:

Advantages	Disadvantages
Reliable and easy to maintain due to their simple design.	Not as powerful as turbocharged engines.
Provide smooth, linear, and predictable power delivery.	Less efficient in high-performance scenarios.

4. Turbocharged Engines

Turbocharged engines are increasingly popular in small, fast cars due to their ability to balance speed and fuel efficiency. By forcing more air into the engine, they boost power without significantly impacting fuel consumption, making them an excellent choice for drivers seeking both performance and economy.

Key Features:

- Turbocharged engines use waste gases to drive a turbine, which forces more air into the engine.
- The denser air allows for a more efficient fuel burn, increasing power output.

Advantages and Disadvantages of a Turbocharged Engine:

Advantages	Disadvantages
Enhanced performance from smaller engines.	Turbo lag can cause slower response at low speeds.

More power for its weight and quicker acceleration.

A more complex design leads to higher repair and maintenance costs.

5. CRDi Engines (Common Rail Direct Injection)

A common rail direct injection (CRDI) diesel engine uses a high-pressure fuel system for precise fuel delivery. This improves combustion efficiency, reduces emissions, and enhances performance and fuel economy.

Key Features:

- It allows for precise and fine atomisation of fuel.
- The system is electronically controlled to ensure optimal timing and fuel efficiency.

Key Components

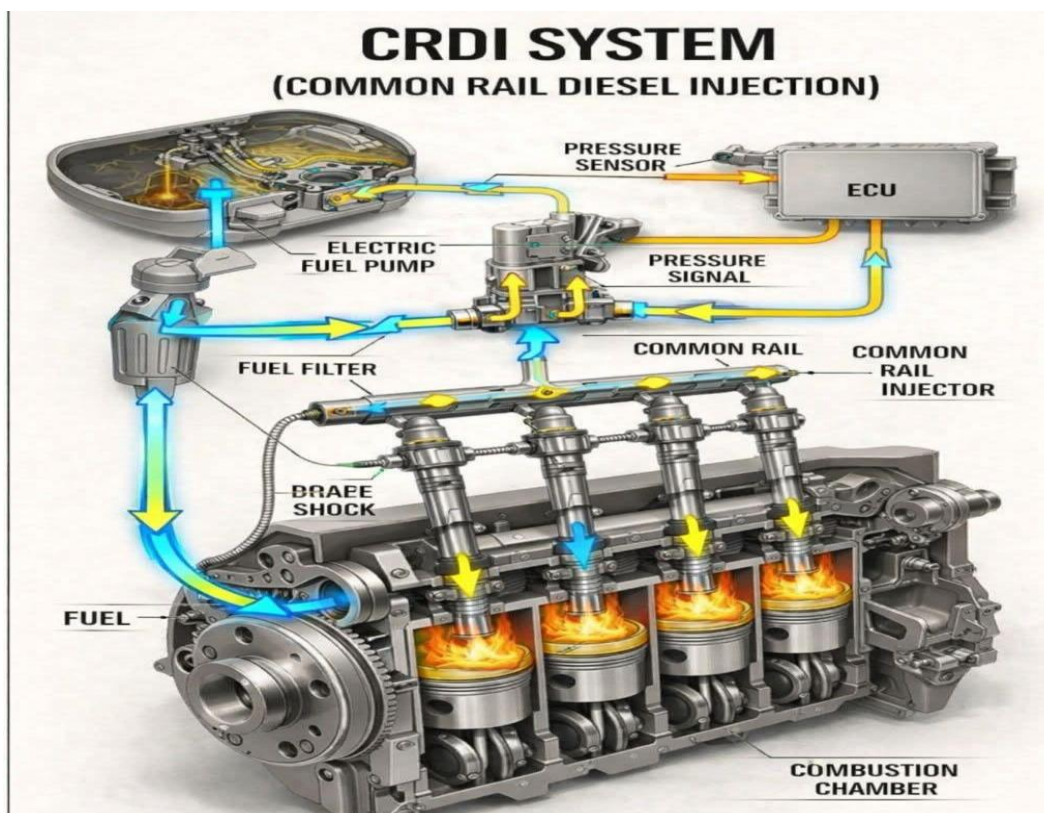

- **High-Pressure Fuel Pump:** Driven by the engine, this pump pressurizes the diesel fuel up to 2,500 bar and sends it to the common rail.
- **Common Rail (Fuel Rail):** A central accumulator (reservoir) that stores the pressurized fuel for all cylinders, ensuring uniform pressure before injection.
- **Electronic Control Unit (ECU/PCM):** The "brain" of the system, it processes data from various sensors (speed, throttle, temperature) to determine precise fuel injection timing and quantity.

- **Injectors (Electro-hydraulic/Piezoelectric):** Electronically controlled by the ECU to inject fuel into each cylinder in a finely atomized spray, often allowing for multiple injections (pilot, main, post) per cycle.
- **Rail Pressure Sensor/Regulator:** Monitors the pressure inside the rail, sending real-time data to the ECU to ensure optimal combustion.
- **Fuel Tank & Filter:** Stores fuel and filters impurities, ensuring clean fuel reaches the high-pressure pump.

Advantages and Disadvantages of a CRDi Engine:

Advantages	Disadvantages
Less pollution and better fuel mileage	Higher manufacturing and repair costs.
Smoother engine operation, making it easier to drive.	Requires clean fuel to prevent injector damage.

6. Engines with MPFI (Multi-Point Fuel Injection)

In petrol engines, MPFI (Multi-Point Fuel Injection) technology is used, with separate injectors for each cylinder to ensure the precise delivery of fuel. This helps achieve optimal combustion, improving power output, fuel efficiency, and reducing emissions.

Key Features:

- It improves combustion efficiency by ensuring better fuel distribution.
- Additionally, it replaces outdated carburettor systems, offering enhanced performance.

Main Components and Functions of MPFI System

- **ECU (Engine Control Unit):** Known as the "brain," this computer receives data from various sensors (airflow, engine temperature, throttle position) to calculate the exact amount of fuel and timing needed for each injector.
- **Fuel Injectors:** These are electromagnetic valves positioned at each intake port. They receive signals from the ECU to spray a fine mist of pressurized fuel directly into the intake port, just before the intake valve opens.
- **Fuel Pump:** An electrical pump that draws fuel from the tank and supplies it to the fuel rail at high pressure to ensure consistent delivery.
- **Fuel Rail:** A small pipe that feeds fuel from the pump to each injector. It serves as a common fuel source for all injectors to ensure equal distribution.
- **Pressure Regulator:** Maintains a consistent, constant fuel pressure in the fuel rail, ensuring the injector sprays the correct amount of fuel, regardless of the fuel pump's pressure fluctuations.

- **Sensors (MAF/MAP, Throttle Position):** Measure air intake volume and pressure. The Mass Air Flow (MAF) sensor or Manifold Absolute Pressure (MAP) sensor helps the ECU calculate the required air-fuel ratio.

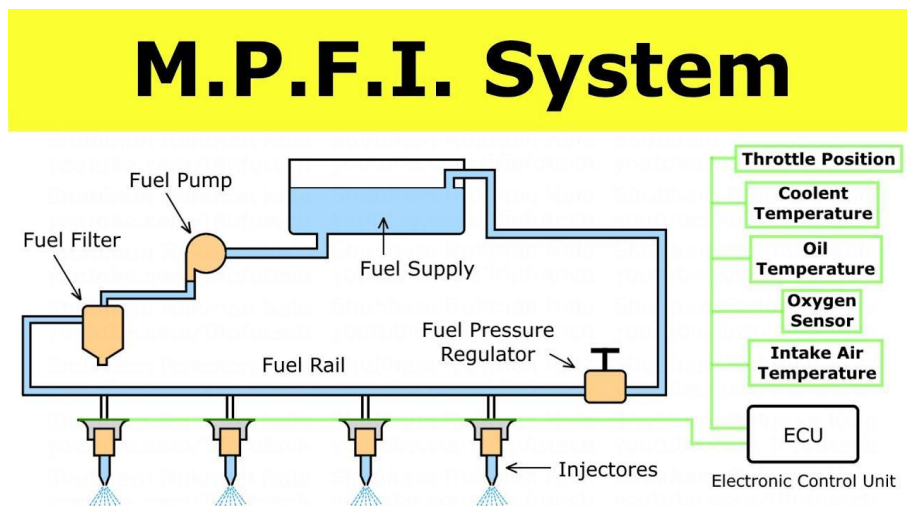

Advantages and Disadvantages of an MPFI Engine:

Advantages	Disadvantages
Easier engine start, especially in cold weather	Complicated electronic systems require proper servicing.
Less pollution and improved fuel economy.	Higher maintenance costs compared to older methods.

7. The Electric Motors

India is turning to electric vehicles (EVs) due to environmental concerns and advancements in battery technology. With improved range, faster charging, and lower running costs, EVs are becoming a practical alternative to traditional vehicles, powered by an electric motor that offers efficient performance with zero emissions.

Key Features:

- It uses electricity instead of conventional fuel for operation.
- It is simple to use and highly reliable with only fewer moving parts.

Advantages and Disadvantages of an Electric Motor:

Advantages	Disadvantages

No pollution from tailpipes and instant power delivery	Limited charging infrastructure across India
Quiet in operation with minimal sound	Higher initial cost and concerns about reliability.

8. The Hybrid Engine

Hybrid engines combine an internal combustion engine with an electric motor, reducing fuel consumption and lowering emissions. This combination allows for better fuel efficiency, making them an eco-friendly option without sacrificing performance.

Key Features:

- It seamlessly switches between conventional fuel and electric modes.
- Additionally, regenerative braking and engine operation help recharge the battery.

Advantages and Disadvantages of a Hybrid Engine:

Advantages	Disadvantages
Excellent fuel economy and environmentally friendly.	More expensive than traditional petrol or diesel cars.
Ideal for city driving with frequent stop-and-go traffic.	Limited availability in the general market.

Difference between petrol and diesel engine

Feature	Petrol Engine	Diesel Engine
Fuel Type	Petrol (gasoline)	Diesel
Ignition Method	Spark ignition (spark plug)	Compression ignition (no spark plug)
Compression Ratio	Lower (typically 8:1 to 12:1)	Higher (typically 14:1 to 25:1)
Fuel Efficiency	Less fuel-efficient	More fuel-efficient (due to higher compression and more fuel density of diesel)
Torque	Lower torque at low RPM	Higher torque at low RPM (good for heavy loads)

Feature	Petrol Engine	Diesel Engine
Power Output	Generally higher power at higher RPM	Generally lower power but strong torque
Engine Noise	Quieter	Noisier (due to higher compression)
Maintenance Cost	Lower maintenance cost	Higher maintenance cost (robust parts)
Engine Lifespan	Shorter lifespan	Longer lifespan (built stronger)
Emission Characteristics	Produces more CO and HC emissions	Produces more NOx and particulates
Applications	Light vehicles, motorcycles	Trucks, buses, SUVs, commercial vehicles

Session II: Routine Maintenance and Settings in Engine

Importance of Regular Maintenance in Engine Performance and Life

Regular engine maintenance is crucial for both performance and longevity, as it ensures optimal fuel efficiency, prevents costly breakdowns, reduces emissions, and maintains the engine's overall health. Performing regular oil changes, replacing filters, and keeping the engine tuned are key practices that minimize wear and tear, extend the engine's life, and can increase its resale value.

Importance for engine performance:

- Enhanced fuel efficiency
- Optimal responsiveness
- Reduced emissions
- Preventing malfunctions

Engine Maintenance Practices

Regular engine maintenance includes changing oil and oil filters on schedule, keeping the air filter clean, monitoring and maintaining coolant levels, and checking belts and hoses for wear. Other important practices are inspecting and replacing spark plugs, checking fuel system components, following the manufacturer's maintenance schedule.

1. Checking and Changing Engine Oil

1. Locate the dipstick
2. Pull out and wipe clean
3. Reinsert and check oil level
4. Drain old oil
5. Replace oil filter
6. Add new oil

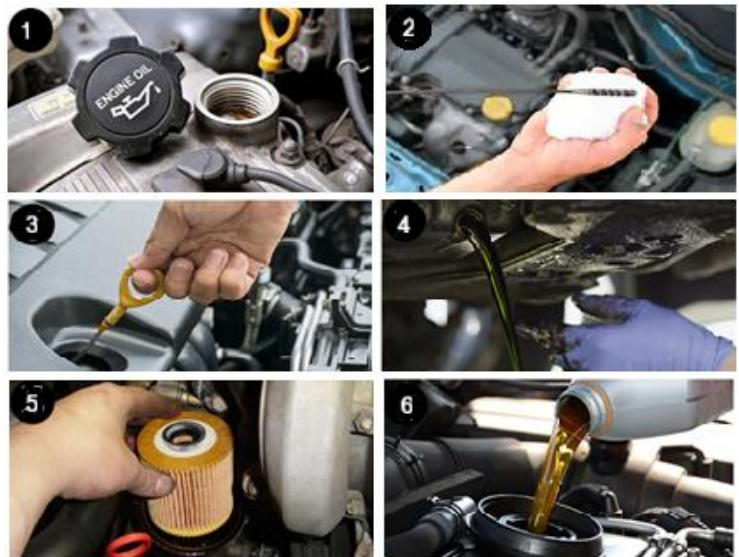

2. Changing Air Filter

1. Find the black plastic box, often near the engine, with a large hose connected to it.
2. Open the housing
3. Remove the old filter
4. Clean the housing
5. Insert the new filter
6. Secure the cover



3. Checking Coolant Level

To check and top up your car's coolant, first ensure the engine is completely cool. Locate the coolant reservoir and check if the level is between the "min" and "max" lines; if not, slowly open the cap, add the correct mixture of coolant and distilled water (or a pre-mixed solution), and close the cap securely.

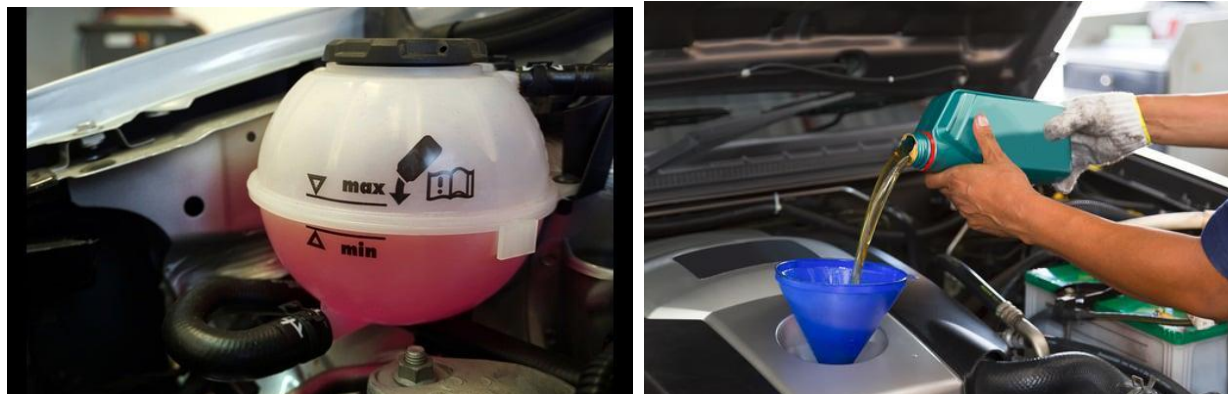

Important Engine Settings

1. Ignition Timing (for Petrol Engines)

It ensures the spark plug fires at the correct point in the piston's compression stroke for optimal power and efficiency.

Process:

1. Warm up the engine to normal operating temperature.
2. Connect a timing light to the No. 1 spark plug lead and battery.
3. Locate the timing marks on the crankshaft pulley and timing cover.
4. Start the engine and aim the timing light at the marks.
5. Check the current timing against manufacturer specifications.
6. Loosen the distributor hold-down bolt slightly (for engines with a distributor).
7. Rotate the distributor slowly—advance or retard timing until the marks align with the specified value.
8. Tighten the bolt and recheck the timing.
9. Re-test under load to confirm proper engine performance.



2. Valve Clearance Adjustment

It ensures correct clearance (gap) between the valve stem and rocker arm/camshaft to maintain proper valve timing and prevent damage.

Process:

1. Allow engine to cool completely.
2. Remove rocker cover(s).
3. Rotate crankshaft until the cylinder being checked is at TDC (Top Dead Centre) on the compression stroke.
4. Insert feeler gauge between rocker arm and valve stem tip.
5. Compare clearance with manufacturer's specification.
6. Adjust (if needed):
 - Loosen lock nut on adjuster screw.
 - Turn screw to set proper clearance.
 - Tighten lock nut and recheck.
7. Repeat for all valves.
8. Reinstall rocker cover and check for oil leaks.

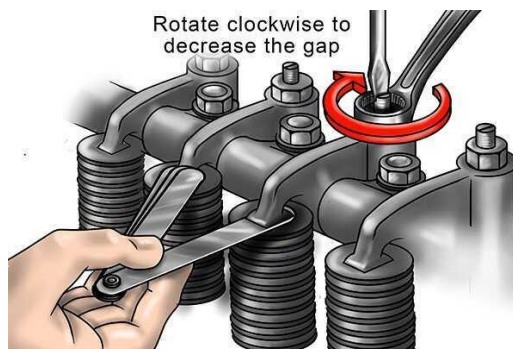

3. Idling Speed Setting

It ensures the engine idles smoothly at the correct RPM, preventing stalling and rough running.

Process:

1. Warm up the engine.
2. Connect a tachometer (if vehicle doesn't have one).
3. Turn off all accessories (AC, lights, etc.).
4. Locate the idle speed screw on the carburetor or throttle body.
5. Adjust screw slowly until the idle speed matches the manufacturer's specification (typically 600–900 RPM).



4. Fuel Mixture / Injection Timing

It optimizes air-fuel ratio for efficiency and emission control.

Process

1. Warm up engine.
2. Locate mixture screw(s) on carburetor.
3. Turn screw(s) slowly in or out to achieve highest steady idle speed or specified CO reading.
4. Re-adjust idle speed if necessary.
5. Recheck emissions (if applicable).



5. Torque Settings for Key Bolts

It ensures bolts are tightened correctly to prevent loosening or damage due to over-tightening.

Process:

1. Obtain torque specifications from service manual (e.g., cylinder head bolts, main bearings, connecting rods, etc.).
2. Clean bolt threads and apply lubricant if specified.
3. Use a calibrated torque wrench.
4. Tighten in correct sequence (especially for cylinder head or manifold bolts).
5. Tighten in stages (e.g., 30%, 60%, 100% of final torque).
6. Recheck final torque after a short run-in period if required.

Common Issues and Quick Diagnostics

1. Smoke Color (Exhaust or Emission)

Smoke Color	Possible Causes	Quick Diagnostic Steps
White Smoke	<ul style="list-style-type: none"> - Coolant leaking into combustion chamber (blown head gasket, cracked head/block) - Unburned fuel in cold conditions 	<ul style="list-style-type: none"> - Check coolant level and oil for milky color (sign of coolant contamination). - Observe if smoke disappears as engine warms up.
Blue Smoke	<ul style="list-style-type: none"> - Burning oil (worn piston rings, valve seals, turbocharger seals) 	<ul style="list-style-type: none"> - Check oil level (may drop quickly). - Inspect spark plugs for oily residue.
Black Smoke	<ul style="list-style-type: none"> - Excessive fuel (rich mixture, dirty air filter, faulty injectors) 	<ul style="list-style-type: none"> - Check and clean air filter.

Smoke Color	Possible Causes	Quick Diagnostic Steps
		- Inspect injectors and fuel pressure regulator.
Gray Smoke	- Oil burning or PCV valve issue	- Inspect PCV valve.

2. Unusual Noises

Noise Type	Possible Causes	Quick Diagnostic Steps
Knocking / Pinging	- Detonation (low-octane fuel, incorrect timing)	- Use higher-octane fuel. - Check ignition timing.
Tapping / Clicking	- Valve train noise (low oil pressure, worn lifters)	- Check oil level and pressure. - Inspect valve clearances.
Grinding	- Bearing failure (main, rod, or accessory)	- Isolate source with mechanic's stethoscope. - Avoid running engine until inspected.
Squealing	- Loose or worn belt	- Inspect belt tension and condition.
Hissing	- Vacuum or exhaust leak	- Listen around intake manifold and hoses for air leaks.

3. Oil Leaks

Location / Observation	Possible Causes	Quick Diagnostic Steps
Under Engine Housing	- Rear main seal, oil pan gasket	- Inspect gasket area and rear seal housing.
Front of Engine	- Crankshaft seal, timing cover gasket	- Check crank pulley area for oil spray.
Top of Engine	- Valve cover gasket	- Wipe area clean and observe for fresh leaks.

Location / Observation	Possible Causes	Quick Diagnostic Steps
Oil Filter / Drain Plug	- Loose or damaged seal	- Tighten to spec; replace filter seal if needed.

Maintenance and common settings of engine of a two wheeler

Maintenance chart of a two-wheeler engine

Sl. No.	Maintenance Task	Description / What to Do	Interval	Tools Required
1	Engine Oil Check & Replacement	Check oil level with dipstick; replace if dark or low. Use recommended grade oil.	Check every 1,000 km; replace every 3,000–5,000 km	Wrench, drain pan, funnel
2	Air Filter Cleaning/Replacement	Remove air filter, clean (foam/paper type) or replace if clogged.	Every 2,000–4,000 km	Screwdriver, compressed air
3	Spark Plug Inspection	Remove spark plug, clean carbon deposits, check gap, replace if worn out.	Every 3,000–5,000 km	Spark plug spanner, feeler gauge
4	Injector Cleaning	Clean jets (carburetor) or check injector spray (FI). Adjust idling speed.	Every 5,000–7,000 km	Carburetor cleaner, screwdrivers
5	Engine Cooling (Air/Oil/Coolant)	Clean cooling fins, check coolant levels (liquid-cooled), replace coolant.	Check monthly; change coolant every 2 years	Brush, coolant, water
6	Valve Clearance Adjustment	Adjust intake/exhaust valve clearance to reduce noise & maintain performance.	Every 8,000–12,000 km	Feeler gauge, spanner
7	Fuel Line & Filter Check	Inspect fuel pipes for cracks; clean/replace fuel filter.	Every 5,000 km	Pliers, replacement hose

Sl. No.	Maintenance Task	Description / What to Do	Interval	Tools Required
8	Exhaust System Inspection	Check for leakages, tighten nuts, clean muffler of carbon.	Every 5,000 km	Spanner, brush
9	Engine Mount Bolt Tightening	Check and tighten engine mountings to reduce vibration.	Every 3,000 km	Spanner set

Engine settings

Setting	How to Check / Adjust (Process)
Idle Speed (RPM)	<ol style="list-style-type: none"> 1. Warm up engine. 2. Use idle screw on carb/throttle body. 3. Adjust until stable RPM is reached.
Air–Fuel Mixture	<ol style="list-style-type: none"> 1. Locate mixture screw on carburetor. 2. Turn clockwise to lean, anticlockwise to rich. 3. Set for smooth acceleration without knocking.
Spark Plug Gap	<ol style="list-style-type: none"> 1. Remove plug. 2. Use feeler gauge to measure. 3. Bend side electrode to adjust.
Valve Clearance	<ol style="list-style-type: none"> 1. Bring piston to TDC (compression). 2. Use feeler gauge. 3. Adjust using tappet screw/locknut.
Cooling System (Liquid-cooled)	<ol style="list-style-type: none"> 1. Check overflow tank. 2. Top up with correct coolant.

Unit IX

Automobiles and Our Environment

Session I: Pollutants from Automobile and BS-6 norms

Introduction

Pollution is of great concern to the human race. As we know that we are not able to conserve our environment properly. If we don't start conserving our environment then our natural resources will be depleted / finished soon. Pollution in any form is dangerous. Pollution of air, water, noise has to be controlled to save our environment. It is necessary for us to adopt national and international emission standards which ensure better utilization of resources. These standards help in controlling the pollution. Governments all over the world are now serious about environment. Therefore, we get emission standards to follow in design & maintenance of automobiles. All the product and services have to follow national standards. Now day's strict measures are being taken by car

designers to adopt Bharat Standard (BS). You must have noticed BS-IV written on vehicles. This is the latest version of emission standards to be followed in India.

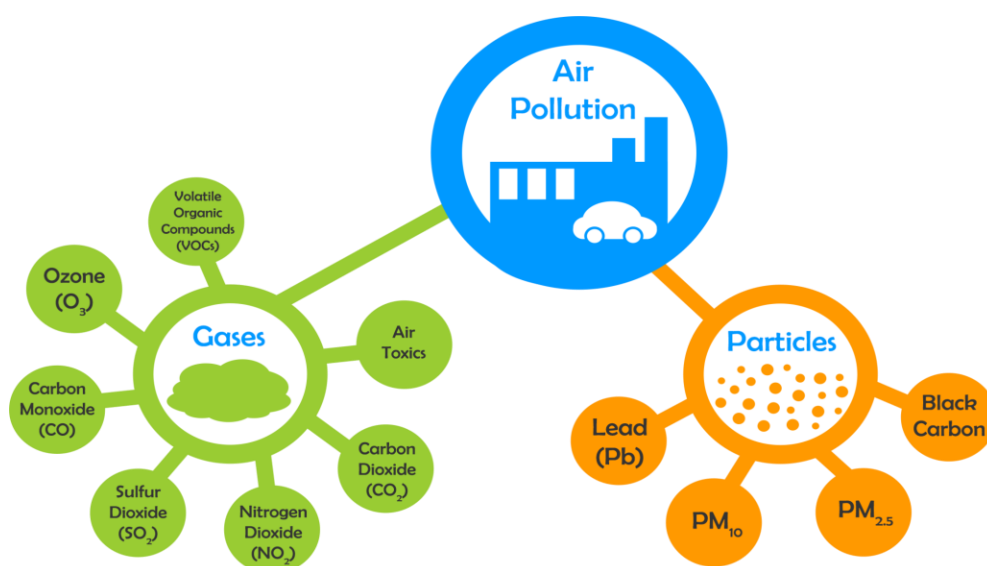

Exhaust

Pollutants in Vehicles

Air pollutants cause injury to all living organisms. They reduce growth and yield of crops and cause premature death of plants. Air pollutants also deleteriously affect the respiratory system of humans and of animals. Harmful effects depend on the concentration of pollutants, duration of exposure and the organism. Smokestacks of thermal power plants, smelters and other industries release particulate and gaseous air pollutants together with harmless gases, such as nitrogen, oxygen, etc. These pollutants must be separated/ filtered out before releasing the harmless gases into the atmosphere.

Vehicle exhaust contains pollutants like carbon monoxide, nitrogen oxides (NO_x), volatile organic compounds (VOCs), particulate matter (PM), and sulfur dioxide (SO_2). These substances are byproducts of incomplete or complete fuel combustion and can contribute to smog, respiratory problems, and climate change.

Major vehicle exhaust pollutants

- **Carbon Monoxide (CO):** A colorless, odorless, and toxic gas produced during incomplete combustion. High concentrations can affect the heart and brain.
- **Nitrogen Oxides (NO_x):** Formed when nitrogen and oxygen in the air react at high temperatures during combustion. They can irritate the lungs and eyes.
- **Volatile Organic Compounds (VOCs):** A group of compounds that are released when fuel is burned. On sunny days, they can react with nitrogen oxides to form ground-level ozone, a major component of smog.
- **Particulate Matter (PM):** A mixture of solid particles and liquid droplets, including soot, that can be seen in exhaust. These particles can damage lungs and enter the bloodstream.
- **Sulfur Dioxide (SO₂):** A gas produced from the combustion of sulfur-containing fuels, such as diesel.
- **Carbon Dioxide (CO₂):** A greenhouse gas that contributes to climate change.
- **Hydrocarbons:** A category of organic compounds found in gasoline that can include toxic substances like benzene.
- **Polycyclic Aromatic Hydrocarbons (PAHs):** Some PAHs are particularly toxic and are found in vehicle exhaust.

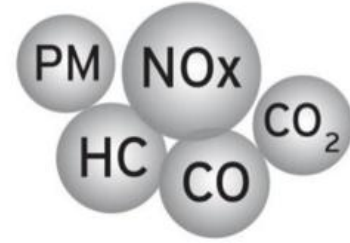

The different types of emissions from vehicles, and a comparison of the relative amounts of selected pollutants released by the latest Euro 6 petrol and diesel vehicles

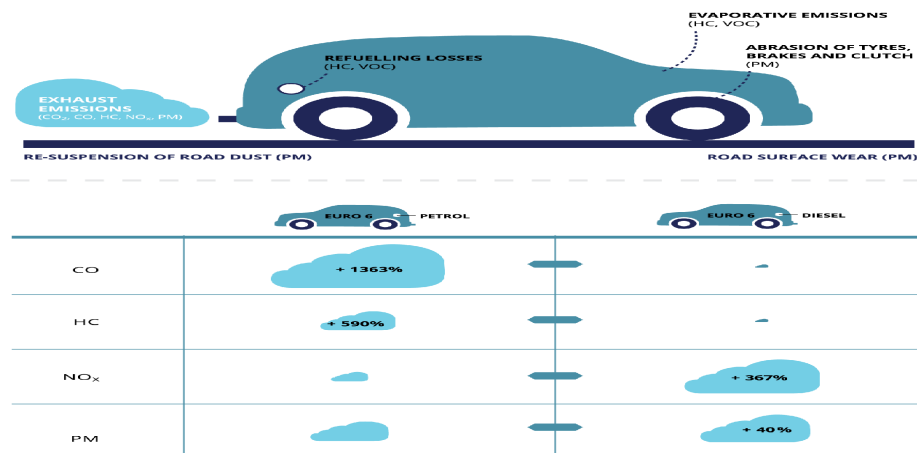

Source: Based on www.fueleconomy.gov

The different types of emissions from vehicles, and a comparison of the relative amounts of selected pollutants released by the latest Euro 6 petrol and diesel vehicles

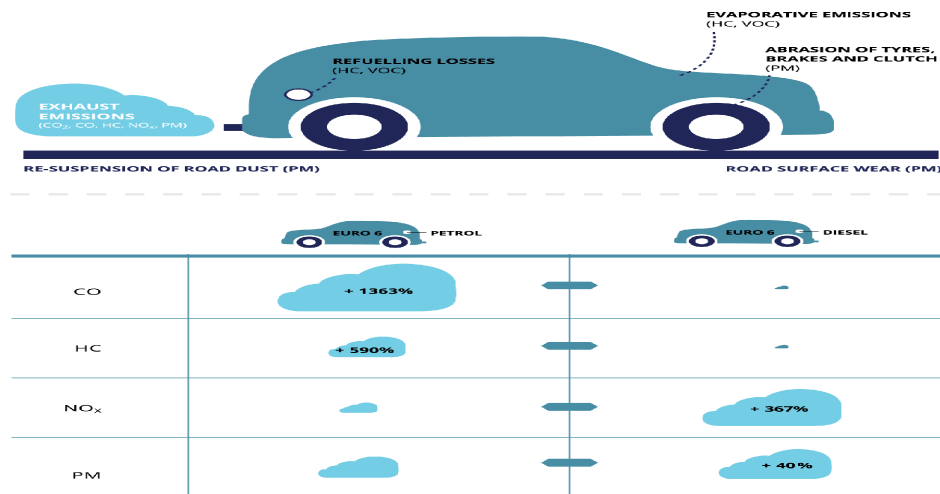

Source: Based on www.fueleconomy.gov

Specific pollutants and their effects

- **Carbon Monoxide (CO):** It blocks oxygen from the brain, heart, and other organs, causing headaches, respiratory problems, and even death in high concentrations.
- **Nitrogen Oxides (NO_x):** It irritates the lungs and weakens the body's defenses against respiratory infections.
- **Particulate Matter (PM):** It can penetrate deep into the respiratory system, causing long-term health issues.
- **Hydrocarbons (HC):** It can cause respiratory irritation and are linked to lung disease and cancer.
- **Sulfur Dioxide (SO₂):** It can form fine particles in the atmosphere, posing a health risk to children and those with asthma.

Automobiles are also a major cause for atmospheric pollution at least in the metro cities. Actually, it is the badly designed and badly maintained automobiles that are a major cause of air pollution. You must have seen on roads a bus or truck or car or tempo releasing black smoke. This is because of poor maintenance of the vehicle. This happens when engine is not burning the fuel completely or properly. It can also happen because of improper mixture of air and fuel or perhaps the poor quality of fuel could be the reason. As the number of vehicles increase on the streets, this problem is now shifting to the other cities also. Proper maintenance of automobiles along with use of lead-free petrol or diesel can reduce the pollutants they emit. Catalytic converters, having expensive metals namely platinum-palladium and rhodium as the catalysts, are fitted into automobiles for reducing emission of poisonous gases. As the exhaust passes through the catalytic converter, unburnt hydrocarbons are converted into carbon dioxide and water. Also, carbon monoxide and nitric oxide are changed to carbon dioxide and nitrogen gas, respectively. Motor vehicles equipped

with catalytic converter should use unleaded petrol because lead in the petrol reduces effectiveness of the catalyst.

Controlling Vehicular Air Pollution: A Case Study of Delhi

With its very large population of vehicular traffic, Delhi leads the country in its levels of air-pollution – it has more cars than the states of Gujarat and West Bengal put together. In the 1990s, Delhi ranked fourth among the 41 most polluted cities of the world. Air pollution problems in Delhi became so serious that a public interest litigation (PIL) was filed in the Supreme Court of India. After being censured very strongly by the Supreme Court, under its directives, the government was asked to take, within a specified time period, appropriate measures, including switching over the entire fleet of public transport, i.e., buses, from diesel to compressed natural gas (CNG).



It was nice that the government of Delhi decided to convert all the buses of to run on CNG by the end of 2002. This resulted in dramatic improvement in the pollution levels.

You may ask the question as to why CNG is better than diesel. The answer is that CNG burns most efficiently and completely. On the other hand, petrol or diesel are partly left un burnt. Moreover, CNG is cheaper than petrol or diesel, cannot be siphoned off by thieves and cannot be adulterated like petrol or diesel. The main problem with switching over to CNG is the difficulty of laying down pipelines to deliver CNG through distribution points/pumps and ensuring uninterrupted supply.

Simultaneously parallel steps are also being taken for reducing vehicular pollution include phasing out of old vehicles, use of unleaded petrol, use of low-sulphur petrol and diesel, use of catalytic converters in vehicles, application of stringent pollution level norms for vehicles, etc.

BS Norms in India

BS norms in India are Bharat Stage emission standards that regulate the amount of air pollutants from internal combustion engines in motor vehicles. India currently uses BS-VI norms, which are similar to European Euro-VI standards. The BS-VI norms significantly lower the levels of pollutants like particulate matter (PM), nitrogen oxides (NO_x), and hydrocarbons (HC) to reduce air pollution.

The following table gives the timeline of the BS norms being implemented in India

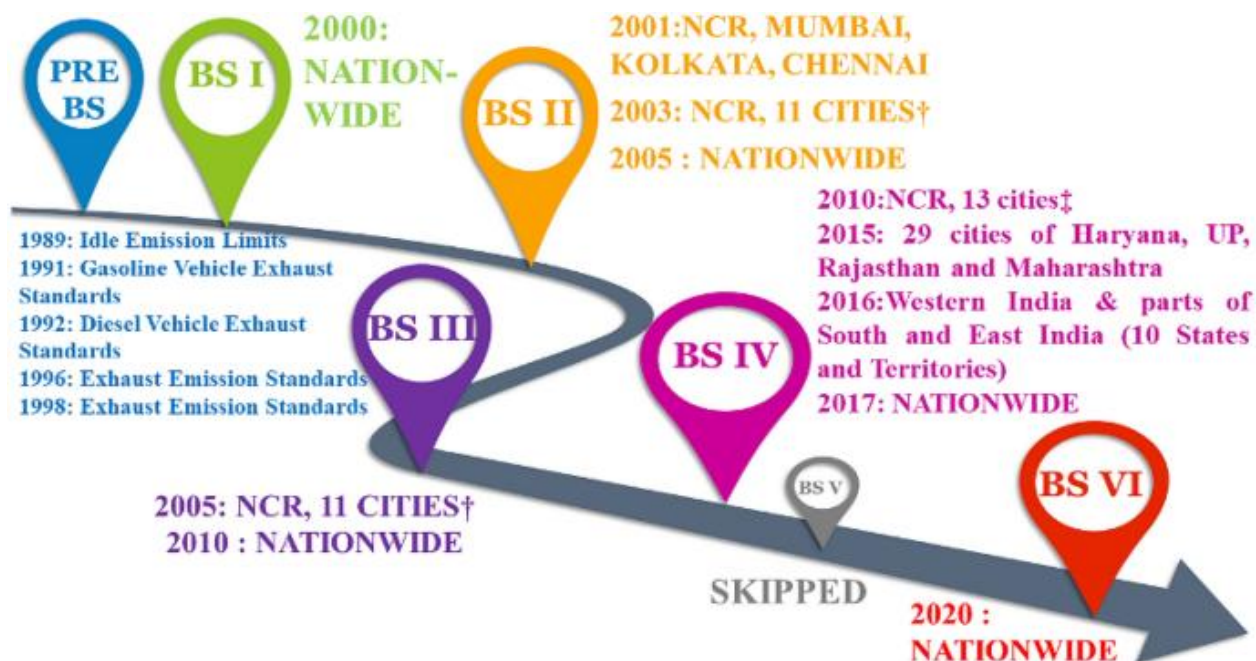

BS Standards	Year/Region
India 2000 (Euro 1)	2000 – Nationwide
BS II (Euro 2)	2001 – Metro cities 2003 – 10 more major cities 2005 – Nationwide
BS III (Euro 3)	2005 – Metros and major cities 2010 – Nationwide
BS IV (Euro 4)	2010 – Metros and major cities 2017 – Nationwide
BS V (Euro 5)	Skipped
BS VI (Euro 6)	2018 – Delhi 2019 – NCR 2020 – Nationwide

BS-6 Norms in India

BS-VI (Bharat Stage VI) emission norms are the highest vehicular emission standards in India, implemented nationwide on **April 1, 2020**, to drastically reduce air pollution by upgrading fuel quality and engine technology. These norms are aligned with European (Euro 6) standards and represent a leapfrog from BS-IV, skipping the intermediate BS-V stage due to critical air quality concerns. These standards mandate cleaner fuel (10 ppm sulphur) and advanced engine

technology, reducing Nitrogen Oxide (NO_x) by ~70% in diesel and 25% in petrol vehicles, with Phase 2 (2023) adding real-driving emission (RDE) tests.



BS6 Phase 2 (Real Driving Emissions - RDE)

The second phase of BS6, which became mandatory on April 1, 2023, requires vehicles to be tested with a Portable Emissions Measurement System (PEMS) to ensure they stay clean under everyday driving conditions. This phase, often called BS6.2 or OBD2, ensures lower emission levels in traffic and varying temperatures.

Core fundamentals of BS-VI norms:

1. Drastic Reduction in Pollutants and Sulphur Content

- **Sulphur Reduction:** The primary shift is lowering sulphur content in fuel (both diesel and petrol) five times—from 50 ppm (parts per million) in BS-IV to a maximum of 10 ppm in BS-VI.
- **Nitrogen Oxide (NO_x) Reduction:** BS-VI cuts NO_x emissions by nearly 70% for diesel engines and 25% for petrol engines.
- **Particulate Matter (PM) Cut:** For diesel vehicles, BS-VI mandates an 82% reduction in particulate matter emissions.
- **Independent HC Limit:** For the first time, independent tailpipe Hydrocarbon (HC) limits are set for two-wheelers, separating them from combined NO_x+HC standards.

2. Technological Upgrades (After-treatment Systems)

- **Diesel Particulate Filter (DPF):** Mandatory on diesel engines to capture fine particulate matter.
- **Selective Catalytic Reduction (SCR):** Used to reduce NO_x emissions using urea-based agents.
- **Lean NO_x Trap (LNT):** Another technology adopted to manage nitrogen oxides in diesel engines.
- **Fuel Injection Engines:** Two-wheelers have transitioned from carbureted engines to electronic fuel injection systems for better combustion control.

3. Mandatory Onboard Diagnostics (OBD)

- BS-VI makes Onboard Diagnostics (OBD) mandatory for all vehicles.
- The OBD unit continuously monitors emission control devices in real-time, storing fault codes to detect malfunctions.
- **OBD Phase-II (2023):** Implemented on April 1, 2023, specifically to monitor catalytic converters and oxygen sensors, signaling the driver via a malfunction light if emissions exceed limits.

4. Real Driving Emissions (RDE) Testing

- Introduced in BS-VI Phase 2, RDE tests ensure that vehicles meet emission standards in real-world driving conditions rather than just in controlled laboratory settings.
- This uses Portable Emission Measurement Systems (PEMS) on public roads to track pollutants like NO₂ and CO in real-time.

Need of BS-VI norms

1. **Severe air pollution levels:** Many Indian cities, including Delhi, have faced dangerously high air pollution. Vehicle emissions are a major contributor, releasing harmful pollutants like particulate matter (PM) and nitrogen oxides (NO_x).
2. **Protection of public health:** Pollutants from vehicles can cause serious diseases such as asthma, lung cancer, and heart problems. BS-VI norms significantly reduce these emissions, improving air quality and reducing health risks.
3. **Reduction in harmful emissions:** BS-VI norms drastically cut:
 - PM (Particulate Matter)
 - NO_x (Nitrogen Oxides)
 - Sulfur content in fuel (from 50 ppm in BS-IV to 10 ppm)

This leads to cleaner exhaust from vehicles.

4. **Adoption of cleaner technology:** To meet BS-VI standards, automobile manufacturers must adopt advanced technologies like:
 - Diesel Particulate Filters (DPF)
 - Selective Catalytic Reduction (SCR)
 - Improved fuel injection systems
5. **Environmental protection:** Lower emissions help reduce environmental damage, including smog formation and ecosystem harm, contributing to a cleaner and more sustainable environment.
6. **Global alignment:** BS-VI brings India in line with international standards such as Euro 6 emission standards, improving the country's environmental credibility and supporting global climate goals.

Impact of BS-VI norms:

- **Stringent Emission Limits:** BS6 standards are comparable to Euro 6 standards, targeting near-zero particulate matter (PM) and sharply lower nitrogen oxides (NO_x).
- **Cleaner Fuel:** BS6 fuel contains only 10 ppm sulphur, compared to 50 ppm in BS4, reducing harmful emissions.
- **Technology Upgrades:** Vehicles now feature Diesel Particulate Filters (DPF), Selective Catalytic Reduction (SCR), and Gasoline Direct Injection to meet the standards.
- **Real Driving Emissions (RDE):** Implemented in April 2023 (Phase 2), this requires cars to pass emission tests in real-world scenarios, not just in laboratory conditions.
- **Onboard Diagnostics (OBD-II):** Mandatory systems that monitor emissions and engine performance in real-time.

- **Consumer Impact:** BS6 vehicles are typically more expensive (₹3,000–₹10,000 for two-wheelers, ₹50,000–₹90,000 for cars) but offer better fuel efficiency, though some diesel models were discontinued.

Major changes in BS-IV to BS-VI

Feature	BS-IV	BS-VI
Year of implementation	2017	2020
Sulphur in fuel	50 ppm	10 ppm
PM emissions (Diesel)	High	82% lower
NOx emissions (Diesel)	High	68% lower
After-treatment	Simple	DPF + SCR + OBD-II
Real Driving Emissions	Not applicable	Introduced (from 2023)

BS-IV Vs BS-VI - Components Comparison

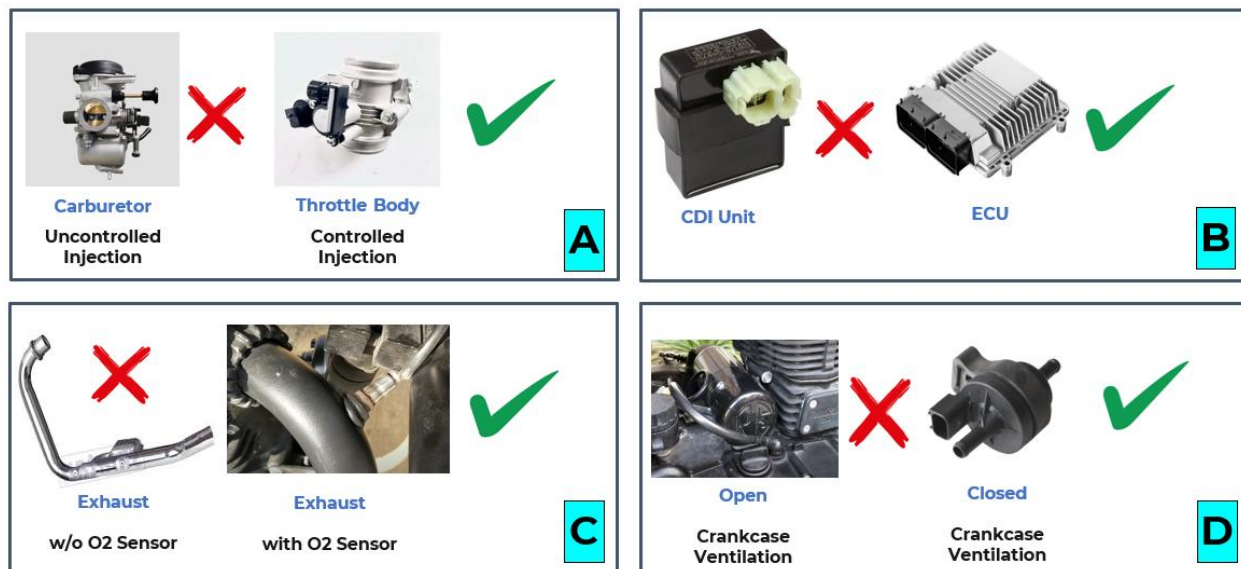

Impact of shifting from BS-IV to BS-VI

- By reducing toxic substances in the air, BS-VI will help reduce air pollution.
- BS-VI will reduce NOx drastically, thus improving air quality.
- NOx is the primary cause of a lot of health issues, especially respiratory issues.
- The lower sulphur in BS VI will help reduce harmful exhaust emissions like NO₂, CO, SO₂.
- Vehicles that have emission control systems will perform even better with BS-VI.
- For old vehicles, BS-VI standards open up an option of retrofitting.

- Oil companies are making significant changes in their oil refining technique. The new standard requires that the use of sulphur in diesel should come down to 10 PPM, whereas according to the BS -II, it was up to 500 PPM. This change will affect the density of diesel oil. The usual density of BS IV fuel diesel ranges from 820 to 845 kg/ cubic metre but now it has to be increased to 860 kg/ cubic metre. The change in density will help improve the quality of oil as well as help reduce air pollution.

Session II: Changes Incorporated to Make Vehicles BS-6 Complaint

BS-VI Vehicles

BS6 (Bharat Stage 6) vehicles are vehicles that comply with the latest and most stringent emission standards set by the Indian government to reduce air pollution. BS-VI vehicles work by using advanced technologies to drastically reduce emissions compared to older standards. This is achieved through a combination of more precise electronic fuel injection systems, cleaner fuel, and sophisticated exhaust treatment systems like Selective Catalytic Reduction (SCR) and Diesel Particulate Filters (DPF). These systems, monitored by On-Board Diagnostics (OBD), work to convert harmful pollutants into less harmful substances, such as nitrogen and water.

Key features of BS6 vehicles

- **Stricter emission limits:** BS6 has significantly tighter limits on pollutants compared to the previous BS4 standards, with the goal of improving air quality.
- **Advanced technologies:** To meet these norms, BS6 vehicles use advanced technologies such as Selective Catalytic Reduction (SCR) and Diesel Particulate Filters (DPF).
- **Cleaner fuel:** The standards also mandate the use of ultra-low sulfur fuel, which has a sulfur content of just 10 mg/kg, a reduction from the 50 mg/kg allowed in BS4 fuel.
- **Improved environmental impact:** By reducing harmful emissions, BS6 vehicles are more environmentally friendly and aim to lower the impact of vehicle pollution on public health.

- **Equivalent to Euro 6:** The BS6 norms are equivalent to the Euro 6 standards used globally, making them comparable to the most advanced emission standards worldwide.

BS-VI Vehicle Components

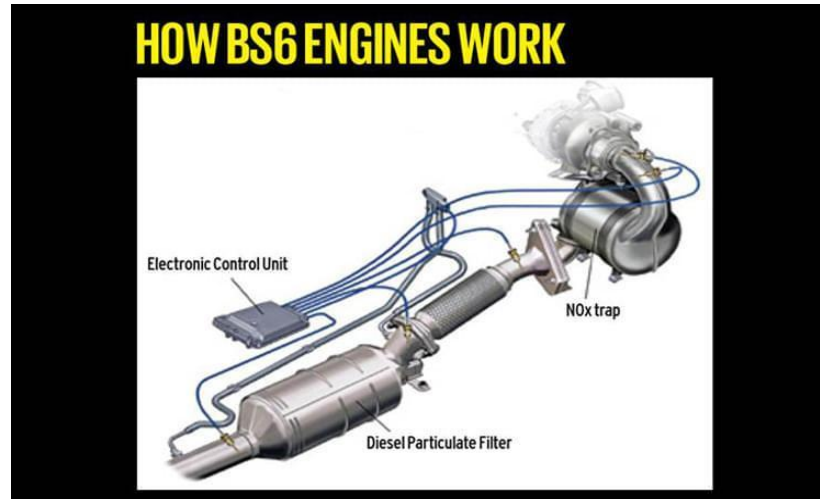

- **Diesel Particulate Filter (DPF):** Traps particulate matter (soot) from diesel exhaust.
- **Selective Catalytic Reduction (SCR):** A system that uses a urea-based solution called AdBlue to convert harmful nitrogen oxides (NOx) into harmless nitrogen and water.
- **Diesel Oxidation Catalyst (DOC):** Helps treat unburnt hydrocarbons (HC) and carbon monoxide (CO).
- **Ammonia Slip Catalyst (ASC):** A catalyst that converts any remaining ammonia (NH₃) into nitrogen and water.
- **On-Board Diagnostics (OBD):** A system that provides real-time monitoring of emissions and engine performance, which is mandatory for all BS-VI vehicles.
- **Advanced Exhaust Gas Recirculation (EGR):** Systems that help manage and reduce emissions.
- **BS-VI Fuel:** BS-VI vehicles require the use of BS-VI grade fuel, which has ultra-low sulfur content, to function correctly and meet emission standards.
- **Engine Control Unit (ECU):** The electronic systems of the vehicle, including the ECU, have been updated to handle the increased complexity and continuously monitor emissions.

Common issues, their causes and solutions in BS-VI vehicles

BS-VI vehicles, designed to reduce pollution with stricter norms and lower sulphur fuel (10 ppm), have introduced advanced technologies that, while eco-friendly, present several common

operational issues. The key challenges involve the Diesel Particulate Filter (DPF) clogging, Selective Catalytic Reduction (SCR) failures, and issues arising from incorrect fuel usage.

Common BS-VI Vehicle Problems

Issue	Cause	Solution
DPF clogging (especially in diesel cars)	Frequent short trips, low-speed driving, incomplete regeneration	Take the car for a 15–20 min highway drive at steady speed to allow DPF regeneration; periodic forced regeneration at service center
AdBlue warning / SCR malfunction	Low or poor-quality Diesel Exhaust Fluid (DEF), sensor issues in SCR	Refill high-quality AdBlue; check sensors and SCR system at authorized service center
Engine warning light (check engine)	Faults in emission sensors (NO _x , oxygen), EGR valve issues	Diagnose using OBD scanner; repair/replace faulty sensors
Reduced engine performance (limp mode)	DPF blockage, SCR fault, turbo or EGR malfunction	Immediate inspection required; clean/replace DPF or repair emission components
Higher maintenance costs	Complex emission systems (DPF, SCR, sensors)	Follow strict service intervals; use recommended fuel and fluids
Poor fuel efficiency	Frequent regeneration cycles, clogged filters, city driving	Maintain steady driving habits; ensure timely servicing
Hard starting or rough idling	EGR valve clogging, injector issues	Clean EGR valve; inspect fuel injectors
Excessive smoke (rare in BS-VI)	Malfunctioning DPF or injectors	Immediate service check; possible DPF replacement
AdBlue crystallization	Low temperatures or poor DEF quality	Use OEM-recommended DEF; periodic system checks
Sensor failures (NO_x/O₂ sensors)	Exposure to heat, contamination, poor fuel quality	Replace faulty sensors; always use high-quality fuel

Session III: PUC Certification

Introduction

Presently, all vehicles need to undergo a periodic emission check (3 months/6 months) at PUC Centers at Fuel Stations and Private Garages which are authorised to check the vehicles. It is mandatory for every vehicle owner to carry a valid Pollution Under Control (PUC) Certificate and maintain the vehicle with in prescribed emission norms.

You must have seen at a nearby petrol pump the Computerised facilities for checking of pollution levels and issue of PUC Certificates (to vehicles meeting emission standards). These authorized Pollution Checking Centres are spread in all cities. At present, number of Centres for petrol driven vehicles and the diesel driven vehicles are functioning. These centres issue Pollution Under Control Certificates (PUC) if the vehicle is found meeting prescribed emission norms. In case the vehicle is found polluting beyond prescribed norms, necessary repairs/ tuning in the vehicle would be required.

PUC certificate

A Pollution Under Control (PUC) certificate is an mandatory document in India certifying that a vehicle's exhaust emissions meet government pollution standards. It confirms emission levels are within legal limits, protecting the environment. Valid for 6 months to a year, it is essential for legal driving and insurance renewal.

In order to get this certificate, a vehicle is put through the PUC test. These tests are generally carried out at petrol pumps in the country.

POLLUTION UNDER CONTROL CERTIFICATE

Authorized By:
 Transport Department Uttar Pradesh



Certificate No.: UP04200170003114
 Registration No.: **UP29AB003**
 Owner Name: MR. SURAJ KUMAR
 SOBI
 Chassis No.: MAB240E19003*****
 Engine No.: K100N71*****
 Class of Vehicle: Motor Car
 Make: MARUTI SUZUKI
 Model: 8100A LTD
 Make: SUZUKI LTD
 Model: AUTO- K10 - L10
 Light Motor
 Vehicle Category: VEHICLE
 Engine Stroke/Cyl: 4/1600
 Date of Registration: 20/04/2012
 Emission Norms: EURO 3
 Fuel: PETROL/LPG
 Date of Testing: 08/Nov/2020
 PUC Equipment: Aro Equipment Pvt
 Manufacturer Name: Ltd
 PUC Equipment Name: Ltd
 Manufacturer Model: GA4040
 Name: GA4040
 PUC Equipment Serial No.: 0501330

TEST RESULT - (PASS)
 VALID U.T.L: 08/May/2021
 PETROL/DIG/LPG DRIVEN VEHICLES
 Certified that the vehicle conforms to the standards prescribed under rule
 115(2) of CMV Rules 1989
 CO Level at 50km/h (Volume) (ppm)
 HC Level at 50km/h (ppm)

PURL	Prescribed Standard CO	Measured Value	Prescribed Standard HC	Measured Value
	0.5	0.55	750.0	54.0

Auto Emission Testing Centre Code: UP042001
 Testing Centre Name: PARAMOUNT SERVICE
 Centre Address: GAADATWALI, FAIZABAD DISTRICT
 AYODHYA, 224001
 Test Conducted By: SHARDEUL AKHILAD
 8000101

Time of Testing: 12:11:07
 Paid to PUC Centre: Rs.40.0



TEST RESULT FOR PETROL/DIG/LPG VEHICLE

CO	CO-CORRECTED	HC	CO2	CO	SM	CO2 TRIP
0.55	0.55	54.0	5.9	12.55	0.0	0.0
DEGREE CERTIFIED						

In case of any Complaint Please Contact U.P. Transport Department Helpline: +91-0520-0191
 This is a computer generated certificate and does not require signature

PUC certificate process



1. **Go to a PUC center:** Visit any authorized emission testing center or an RTO-approved center.
2. **Get the test:** An operator will place a probe in your vehicle's exhaust pipe to check the emission levels.
3. **Generate the certificate:** If the emissions are within the permissible limit, the operator will generate a PUC certificate.
4. **Pay and collect:** Pay the applicable fee and receive the physical certificate.

